

Information Sheet

USPA-350SS Wire Cutting Instructions

SAFETYSUB.

AL9CU – For Wet or Damp Locations (DIRECT BURIAL)

THE INSULATION DIAMETER OF THE CONDUCTOR WILL DETERMINE WHERE THE WIRE ADAPTOR IS TO BE CUT. THE INSIDE OF THE WIRE ADAPTOR IS TAPERED. THE DECIMAL NUMBER ON THE OUTSIDE RING IS THE DIAMETER OF THE INSIDE OF THE ADAPTOR WHERE THE ARROWS POINT. TO INSURE PROPER SEATING THE ADAPTOR MUST FIT SNUG ON THE WIRE INSULATION. THE GUIDE BELOW IS FOR STANDARD WIRE INSULATION. IF YOUR CONDUCTOR INSULATION IS DIFFERENT THAN THE GUIDE YOU MUST DETERMINE WHERE THE ADAPTOR IS CUT BASED ON WHETHER THE INSULATION DIAMETER IS LARGER OR SMALLER THAN THE GUIDE.

THE WIRE ADAPTOR MUST BE CUT STRAIGHT AT 90°.

FOR WIRE SIZES LARGER THAN 4/0 OR CONDUCTOR INSULATION DIAMETER LARGER THAN .72, THE WIRE ADAPTOR IS NOT REQUIRED.

CUT HERE FOR 4/0 WIRE, INSULATION DIAMETER .63 TO .72

CUT HERE FOR 3/0 WIRE, INSULATION DIAMETER .59 TO .65.

CUT HERE FOR 2/0 WIRE, INSULATION DIAMETER .53 TO .58.

CUT HERE FOR 1/0 WIRE, INSULATION DIAMETER .49 TO .55.

CUT HERE FOR #1 AWG WIRE, INSULATION DIAMETER .45 TO .50.

CUT HERE FOR #2 OR #3 AWG WIRE, INSULATION DIAMETER .35 TO .46.

CUT HERE FOR #4 AWG. WIRE, INSULATION DIAMETER .32 TO .37.

CUT HERE FOR #6 OR #8 AWG. WIRE, INSULATION DIAMETER .24 TO .33.

CUT HERE FOR #10 AWG. WIRE, INSULATION DIAMETER .21 TO .25.

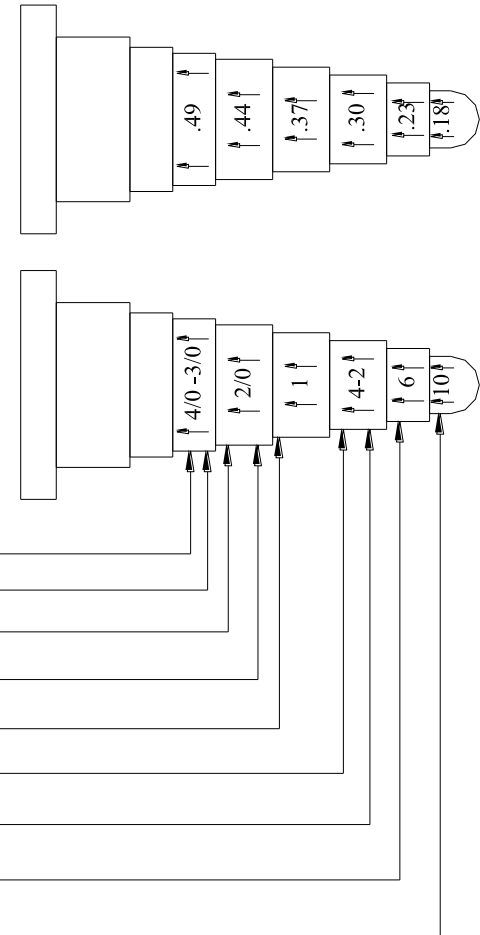

Information Sheet

USPA-350SS Wire Cutting Instructions

SAFETYSUB.

AL9CU – For Wet or Damp Locations (DIRECT BURIAL)

THE INSULATION DIAMETER OF THE CONDUCTOR WILL DETERMINE WHERE THE WIRE ADAPTOR IS TO BE CUT. THE INSIDE OF THE WIRE ADAPTOR IS TAPERED. THE DECIMAL NUMBER ON THE OUTSIDE RING IS THE DIAMETER OF THE INSIDE OF THE ADAPTOR WHERE THE ARROWS POINT. TO INSURE PROPER SEATING THE ADAPTOR MUST FIT SNUG ON THE WIRE INSULATION. THE GUIDE BELOW IS FOR STANDARD WIRE INSULATION. IF YOUR CONDUCTOR INSULATION IS DIFFERENT THAN THE GUIDE YOU MUST DETERMINE WHERE THE ADAPTOR IS CUT BASED ON WHETHER THE INSULATION DIAMETER IS LARGER OR SMALLER THAN THE GUIDE.

THE WIRE ADAPTOR MUST BE CUT STRAIGHT AT 90°.

FOR WIRE SIZES LARGER THAN 4/0 OR CONDUCTOR INSULATION DIAMETER LARGER THAN .72, THE WIRE ADAPTOR IS NOT REQUIRED.

CUT HERE FOR 4/0 WIRE, INSULATION DIAMETER .63 TO .72

CUT HERE FOR 3/0 WIRE, INSULATION DIAMETER .59 TO .65.

CUT HERE FOR 2/0 WIRE, INSULATION DIAMETER .53 TO .58.

CUT HERE FOR 1/0 WIRE, INSULATION DIAMETER .49 TO .55.

CUT HERE FOR #1 AWG WIRE, INSULATION DIAMETER .45 TO .50.

CUT HERE FOR #2 OR #3 AWG WIRE, INSULATION DIAMETER .35 TO .46.

CUT HERE FOR #4 AWG. WIRE, INSULATION DIAMETER .32 TO .37.

CUT HERE FOR #6 OR #8 AWG. WIRE, INSULATION DIAMETER .24 TO .33.

CUT HERE FOR #10 AWG. WIRE, INSULATION DIAMETER .21 TO .25.

