

P9207 Cutting Alignment Gauge

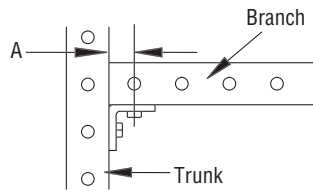

The cutting alignment guide ensures correct cutting of branch members when used with fittings to make connections. Refer to the table of page 73 for the appropriate value for "A" for cutting.

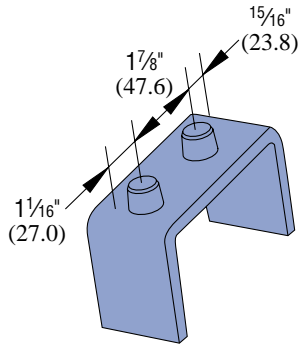
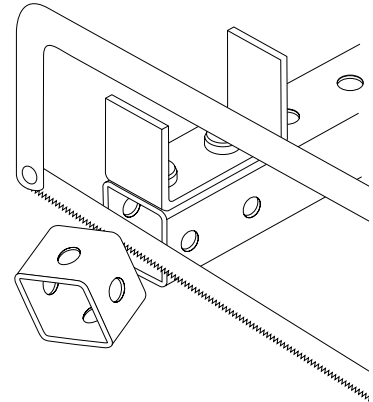

P9324

Wt/100 pcs: 78 Lbs (35.0 kg)

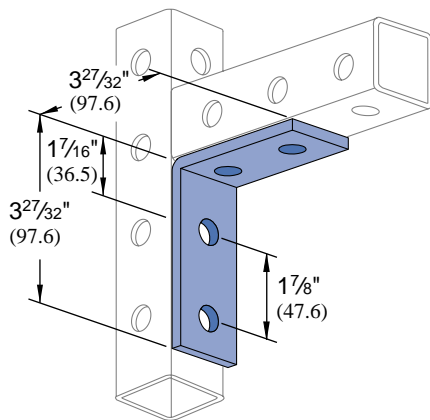

Standard Dimensions for 1 5/8" (41 mm) width series channel Fittings (Unless Otherwise Shown on Drawing)

Hole Diameter: 9/16" (14.3mm); **Hole Spacing - From End:** 13/16" (20.6 mm); **Hole Spacing - On Center:** 1 7/8" (47.6 mm); **Width:** 1 5/8" (41mm); **Thickness:** 1/4" (6.4mm)



UNISTRUT®

TELESTRUT® SYSTEM

Telescoping Tube 67
 Connection Methods 70
 Specialized Fittings 71
 Cutting Chart 73

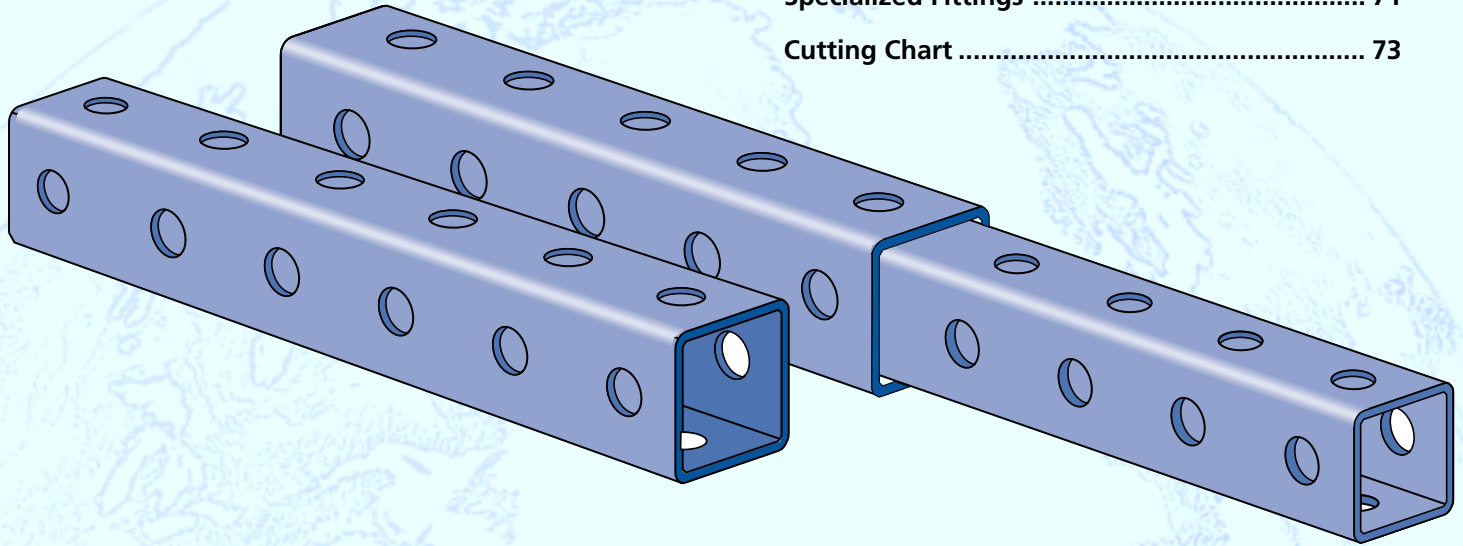

MATERIAL

Unistrut channels are accurately and carefully cold formed to size from low-carbon strip steel.

All spot-welded combination members, except P1001T, are welded 3" (76 mm) maximum on center.

STEEL: PLAIN

12 Ga. (2.7 mm), 14 Ga. (1.9 mm) and 16 Ga. (1.5 mm)
 ASTM A1011 SS GR 33.

STEEL: PRE-GALVANIZED

12 Ga. (2.7 mm), 14 Ga. (1.9 mm) and 16 Ga. (1.5 mm)
 ASTM A653 GR 33.

FINISHES

Fittings are available in: Perma-Green II (GR), electro-galvanized (EG), conforming to ASTM B633 Type III SC1; Hot-dipped galvanized (HG), conforming to ASTM A123 or A153 and plain (PL).

DESIGN BOLT TORQUE

BOLT SIZE	1/4"	5/16"	3/8"	1/2"	5/8"	3/4"
FOOT LBS.	6	11	19	50	100	125
N·m	8	15	25	70	135	170

DIMENSIONS

Imperial dimensions are illustrated in inches. Metric dimensions are shown in parenthesis or as noted. Unless noted, all metric dimensions are in millimeters and rounded to one decimal place.

DESIGN LOAD

Design load data, where shown, is based on the ultimate strength of the connection with a safety factor of 2.5, unless otherwise noted.