

TORK® TIME SWITCH MECHANISM FOR POOL PANELS

E312471

MODEL#: P1104FM-M	240 VOLT, 24-HOUR MECHANICAL TIME SWITCH MECHANISM w/ Fireman Switch (Heater Cutoff Switch)	CAI[®] US
CONTACT CONFIGURATION:	DPST (Double Pole Single Throw), (2) NO (Normally Open Contacts), (1) NC (Normally Closed Contact)	
TIME SWITCH RATING:	40A Resistive/Inductive per pole, 7.5HP @ 240V (NO Contacts); 1.5A General Purpose/Resistive	
MODES OF OPERATION:	3 Operating modes available: Timer/AUTO, OFF/Standby, ON	
FIREMAN SWITCH RATING:	15A, SPST @ 120V	
AUTOMATIC OPERATION:	Time Switch can be switched on or off in 15 minute increments for a multitude of on/off operations per 24 hour period. See below for details on "modes of operation".	

IMPORTANT SAFETY INSTRUCTIONS

READ & FOLLOW ALL INSTRUCTIONS – SAVE THESE INSTRUCTIONS

ATTENTION: Read carefully before attempting to install this control. Failure to comply with instructions could result in personal injury and/or property damage!

1. This control must be installed in accordance with National and Local Electrical Codes.
2. Disconnect power at main panel before installing or servicing this device.
3. USE COPPER CONDUCTORS ONLY
4. Do not exceed the ratings of this device, and current capacity of conductors
5. This control should not operate any equipment which would cause bodily injury or property damage should it be activate unexpectedly.

INSTALLATION & WIRING INSTRUCTIONS

1. To install Time Switch into control panel, insert lower back edge of mechanism into Universal mounting plate located in control panel. Push top front edge of mechanism down into the mounting plate. You will here a click indicating that the Time Switch is securely attached to universal mounting plate.
2. To wire switch follow the wiring diagram provided.
3. Use solid or stranded COPPER wire only.
4. Strip the supply and load wires by removing 1/2 inch of insulation.
5. Insert the wires under the proper terminal plates and tighten the screws firmly.

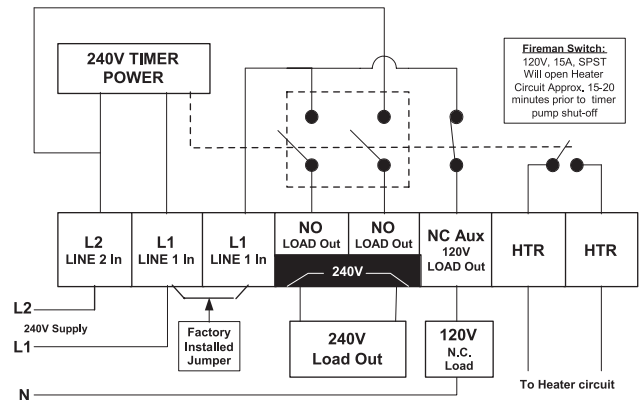

PROGRAMMING & OPERATING YOUR TIME SWITCH MECHANISM

SETTING THE TIME: Rotate clock face in a clockwise direction until proper time is displayed. In order to properly set time for AM or PM, verify that black arrow on clock face matches the correct 24-hour clock setting (example: 6=6AM, 18=6PM). If it does not, rotate clockwise 1 complete turn for correct AM or PM setting.

SETTING "ON" and "OFF" TIMES: Set the captive trippers for desired on/off sequence required.

- OFF-Push trippers IN (toward center of clock)
- ON-Push trippers OUT (away from center of clock)

MODES OF OPERATION: (Using 3-Position Rocker Switch)

- Timer/AUTO: Automatic Time Switch operation according to captive tripper's on/off settings
- OFF/Standby: Maintains proper clock time and Time Switch program settings during periods of non-use.
- ON: Used to override Timer/AUTO mode. User can turn the Time Switch ON. Time Switch will remain ON until the user switches back to TIMER/AUTO or OFF mode.



MODES

- TIMER/AUTO
- OFF/STANDBY
- ON

NOTE: There is no adjustment to fireman switch