

DRAWING NO.
SD206499-01

| CATALOG NUMBER | I.P.S. PIPE ACCOMMODATED | | COPPER CABLE ACCOMMODATED | | H | J | W | RECOMMENDED TIGHTENING TORQUE | |
|----------------|--------------------------|-------------|---------------------------|--------------------------------|-------------|----------|-------------|-------------------------------|------------------|
| | NOMINAL O.D. | ACTUAL O.D. | | AWG | | | | | METRIC WIRE SIZE |
| | | (in) | [mm] | | | | | | |
| GAR3902 | 1/2"-1" | .840-1.32 | [22-33] | 4 STR(.232) - 4/0 STR(.528) | 3.50 [89] | 3/8"-16" | 3.25 [83] | 200 Lb*in [22.5 N*m] | |
| GAR3903 | 1-1/4"-2" | 1.66-2.38 | [43-60] | | 4.00 [102] | | 4.25 [108] | | |
| GAR3904 | 2-1/2"-3-1/2" | 2.88-4.00 | [74-101] | | 6.50 [165] | | 6.00 [152] | | |
| GAR3905 | 4"-5" | 4.50-5.56 | [115-141] | | 7.50 [191] | | 7.50 [191] | | |
| GAR3906 | 6" | 6.62 | [168] | | 8.50 [216] | | 8.62 [219] | | |
| GAR3907 | 8" | 8.62 | [218] | | 10.00 [254] | | 10.62 [270] | | |
| GAR3908 | 10" | 10.75 | [273] | | 12.00 [305] | | 12.75 [324] | | |
| GAR3909 | 12" | 12.75 | [323] | | 14.00 [356] | | 14.75 [375] | | |

| REV | DATE | DESCRIPTION | ECO | BY | CHK |
|-----|------------------------|--|-------|----|-----|
| B | 08/13/2013 00:00:00 AM | NOTE 5 & FILM 5 ADDED FOR TIN PLATING. | 32843 | BD | MA |

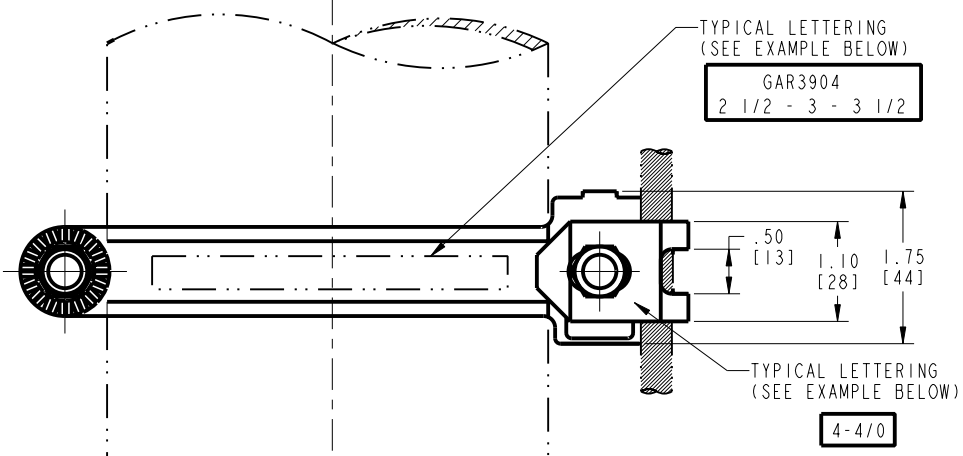
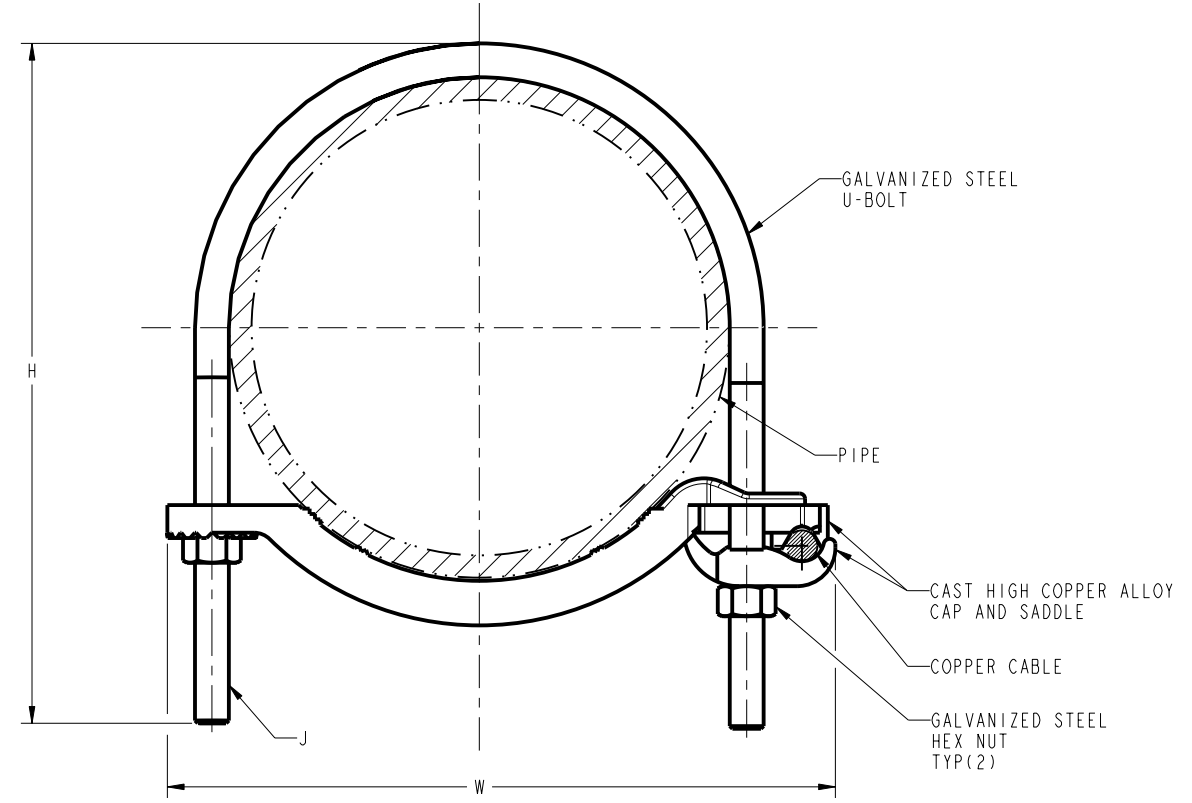

- NOTES:
1. MATERIAL: AS NOTED.
 2. UL 467 LISTED, FILE NO. E9999. ACCEPTABLE FOR DIRECT BURIAL.
 3. CSA C22.2 NO. 65 LISTED, FILE NO. 42862.
 4. DIMENSIONS IN BRACKETS [] ARE IN MILLIMETERS ROUNDED OFF TO THE NEAREST MILLIMETER, UNLESS OTHERWISE NOTED AND ARE FOR REFERENCE ONLY.
- 5 ADD SUFFIX "TN" TO THESE CATALOG NUMBERS FOR TIN-PLATED VERSIONS.

| | | | |
|---|--|--------------------------|------------|
| TO ORDER BURNDY® PRODUCTS CALL | | GAR ASSEMBLY | |
| UNITED STATES 1-800-346-4175 (LONDONDERRY, NH) | | ITEM NO: -- | SCALE: 1:1 |
| CANADA: 1-800-361-6975 (QUEBEC) 1-800-387-6487 (ALL OTHER PROVINCES) | | CAT. NO: GAR390- (TABLE) | REV |
| FOR PRODUCT INFO: http://www.burndy.com | | DRAWN BY: MP 11/20/90 | B |
| | | CHECKER: ATM 11/20/90 | |
| | | DSN APPVL: KW 11/20/90 | |
| | | MFG APPVL: -- | |
| | | QA APPVL: AL 11/20/90 | |
| | | MKT APPVL: -- | |
| | | PROJ #: | |
| | | SIZE: D | |
| | | DOCUMENT TYPE: Sales | |
| | | REL LEVEL: Released | |
| | | DRAWING NO: SD206499-01 | |
| | | SHEET 1 OF 1 | |

REV: PE0200