







ELC-EX08NNDR/T ELC-EX16NNDR/T ELC-EX08NNDN ELC-EX08NNAN Instruction Sheet ELC-EX08NNNR/T ELC-EX06NNNI

Digital Input Digital Output Module

WARNING

-  This Instruction Sheet provides descriptions for electrical specifications, installation & wiring.
-  This is an OPEN TYPE Controller. The ELC should be kept in an enclosure away from airborne dust, humidity, electric shock risk and vibration. Also, it is equipped with protective methods such as some special tools or keys to open the enclosure, so as to avoid the hazard to users and the damage to the ELC. Do NOT touch terminals when power on.
-  DC type ELC never connects the AC main circuit power supply to any of the input/output terminals, as it will damage the ELC. Check all the wiring prior to power up.
-  Power, input and output (I/O) wiring must be in accordance with Class 1, Div. 2 wiring methods - Article 501-10(B)(1) of the National Electrical Code.
-  Suitable for use in Class 1, Division 2, Groups A, B, C, D or Non-Hazardous locations only.
-  Warning – Explosion hazard - Substitution of components may impair suitability for Class 1, Division 2.
-  Warning – Explosion hazard - Do not disconnect equipment unless power has been switched off or the area is known to be Non-Hazardous.

1 INTRODUCTION

1.1. Product Profile and Outline

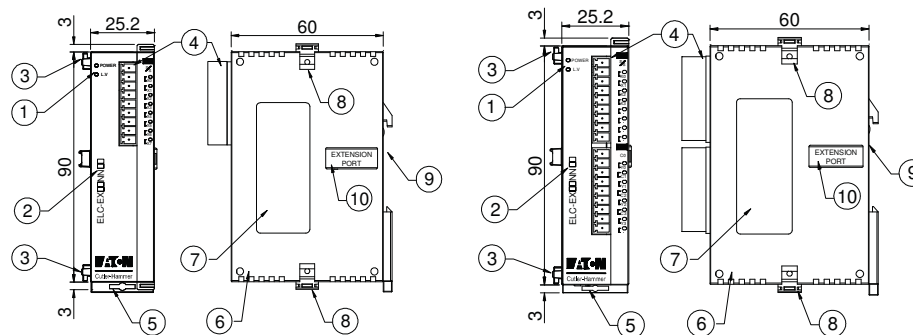

1. Status indicator (Power and low voltage)	2. Model Name
3. Extension unit clip	4. Input/output terminal
5. DIN rail clip	6. Mounting hole of the extension unit
7. Nameplate	8. Extension unit clip
9. DIN rail (35mm)	10. Extension port

1.2. Model Numbers

Model	Input Unit		Output Unit		Dimensions (mm)	Mass(g)
	Point	Type	Point	Type		
ELC-EX08NNDR	4	DC Type Sink/Source	4	Relay	25.2 X 90 X 60	141
ELC-EX16NNDR	8		8			
ELC-EX08NNDT	4		Transistor	4		
ELC-EX16NNDT	8			8		
ELC-EX08NNAN	8	100~120VAC	0	None		141
ELC-EX08NNDN	8	DC Type Sink/Source	0	None		162
ELC-EX08NNNR	0		8	Relay		136
ELC-EX08NNNT	0		8	Transistor		154
ELC-EX06NNNI	0		6	Relay	200	

2 ELECTRICAL SPECIFICATIONS

2.1 Electrical Specification

Item	Model	EX08NNDN EX08NNAN	EX08NNNR/T	EX08NNDR/T	EX16NNDR/T	EX06NNNI
Power Supply Voltage		24VDC (-15%~+20%) (the counter-connection protection towards the DC input power polarity is included)				
Motion Specifications		Within 5ms of the momentary power loss, the device will keep on operating				
Maximum Power Consumption		1W	1.5W	1.5W	2W	1.5W
Insulation Resistance		Above 5 M Ω (500VDC between the ground and all the I/O points)				
Noise Immunity		ESD(IEC 61131-2, IEC 61000-4-2): 8KV Air Discharge EFT(IEC 61131-2, IEC 61000-4-4): Power Line: 2KV, Digital I/O: 1KV, Analog & Communication I/O: 1KV RS(IEC 61131-2, IEC 61000-4-3): 26MHz~1GHz, 10V/m				
Vibration/Shock Immunity		International Standard Regulations: IEC61131-2, IEC 68-2-6 (TEST Fc)/ IEC61131-2 & IEC 68-2-27 (TEST Ea)				
Operation/Storage Environment		Operation: 0 $^{\circ}$ C ~55 $^{\circ}$ C (temperature), 50~95% (humidity), pollution degree: 2; Storage: -25 $^{\circ}$ C ~70 $^{\circ}$ C (temperature), 5~95% (humidity)				
Agency Approvals		UL508 UL1604, Class1,Div2 Operating temperature code: T5 European community EMC Directive 89/336/EEC and Low Voltage Directive 73/23/EEC				

2.2 Input/Output Specification

Electrical Specification DC Input Point			
Item	Input type	DC Type	AC Type
Input Type		DC (SINK or SOURCE)	-
Input impedance		-	14.5 Kohm/50Hz 12 Kohm/60Hz
Input Voltage/Current		24VDC 5mA	85~132VAC 50~60Hz 9.2 mA 110VAC/60Hz
On/Off Voltage Level		Off \rightarrow On, above 16.5 VDC	above 80VAC
		On \rightarrow Off, below 8 VDC	below 30VAC
Response Time		Default 10ms (Adjustable range of 0~15ms could be selected through D1020)	Off \rightarrow On < 15 ms On \rightarrow Off < 20 ms
Circuit isolation/Operation indication		Photocoupler/LED On	
Maximum Off Current		1.8 mA	2 mA

Electrical Specification of Output Point				
Item	Output Type	Relay-R	Relay-R (*1)	Transistor-T
Current Spec.		1.5A/1 point (5A/COM)	6A/1 point	55 $^{\circ}$ C 0.1A/1 point, 50 $^{\circ}$ C 0.15A/1 point 45 $^{\circ}$ C 0.2A/1 point, 40 $^{\circ}$ C 0.3A/1 point
Voltage Spec.		250VAC, below 30VDC	250VAC, below 30VDC	30VDC
Max. Loading		75VA (Inductive)	240VA (Inductive)	9W
		90 W (Resistive)	150 W (Resistive)	
Response Time		About 10 ms	About 10 ms	Off \rightarrow On 15us On \rightarrow Off 25us

*1: Only for model ELC-EX06NNNI

Terminal Layout

ELC-EX08NNDN	ELC-EX08NNAN	ELC-EX08NNNR ELC-EX08NNNT	ELC-EX08NNDR ELC-EX08NNDT	ELC-EX16NNDR ELC-EX16NNDT	ELC-EX06NNNI

3.1. System Assembly

Procedure:

1. Open the extension cover on the side of the unit with a screw driver so that the external connector is exposed.

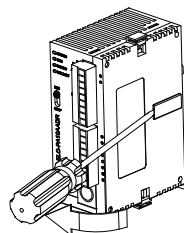

2. Raise the extension hooks on the top and bottom sides of the unit with a screwdriver.

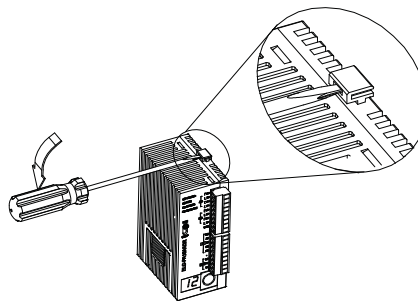

3. Align the pins and holes in the four corners of the control unit and extension unit, and insert the pins into the holes so that there is no gap between the units.

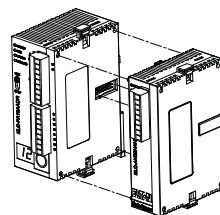

4. Press down the expansion hooks raised in step 2 to secure the unit.

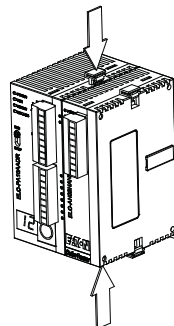

3.2. Installation of the DIN rail

The ELC can be secured to a cabinet by using the DIN rail that is 35mm high with a depth of 7.5mm. When mounting the ELC on the DIN rail, be sure to use the end bracket to stop any side-to-side motion of the ELC, thus to reduce the chance of the wires being pulled loose. At the bottom of the ELC is a small retaining clip.

To remove it, pull down the retaining clip and gently pull the ELC away from the DIN rail. As shown on the right:

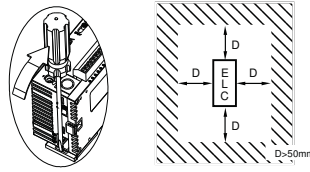

When installing the ELC, make sure that it is installed in an enclosure with sufficient space (as shown on the right) to its surroundings so as to allow heat dissipation.

3.3. Input/Output points numbering order

No matter how many points of MPU, the input of the first I/O extension unit will start from X20, output will start from Y20.

System combined Example:



MPU EXT1 EXT2 EXT3 EXT4

ELC	Models	Input Points	Output Points	Input Numbering	Output Numbering
MPU	PA/PB/PC	8	4/6	X0~X7	Y0~Y5
EXT1	EX16NNDT	8	8	X20~X27	Y20~Y27
EXT2	EX08NNDN	8	0	X30~X37	-
EXT3	EX06NNNI	0	6	-	Y30~Y35
EXT4	EX08NNDR	4	4	X40~X43	Y40~Y43

Extension unit 3 ELC-EX06NNNI will be used as 8 outputs, the higher 2 numbers of output points have no corresponding output points.

Extension unit 4 ELC-EX08NNDR will be used as 8 input points/8 output points, the higher part numbers of inputs points and output points have no corresponding input/output points. It is recommended to place them at the end of serial wiring, so that I/O points numbering will be continuous.

3.4. Wiring

Notes:

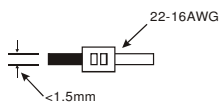

1. Please use 22-16AWG (1.5mm) wiring (either single or multiple core) for I/O wiring terminals. The specification for the terminals is as shown on the left. ELC terminal screws should be tightened to 1.95 kg-cm (1.7 lb-n). Use Copper Conductor Only, 60/75 °C.
2. I/O signal wires or power supply should not run through the same multi-wire cable or conduit.

3.5. Input Point Wiring

There are two types of DC type wiring: SINK and SOURCE, defined as follows:

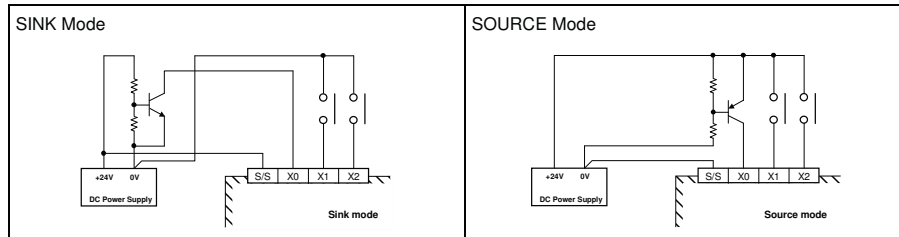

3.6. AC Type Wiring

Input Circuit Connection	110V AC Input Specifications	
<p>ELC-EX08NNAN</p>	Input voltage	85~132VAC 50~60Hz
	Input impedance	14.5Kohm/50Hz 12Kohm/60Hz
	Input current	9.2mA 110VAC/60Hz
	On/Off Voltage Level	above 80VAC below 30VAC
	Response time	Off → On < 15 ms On → Off < 20 ms
	Circuit isolation/Operation indication	Photocoupler/LED On

3.7. Output Point Wiring

■ The Relay Output Circuit Wiring

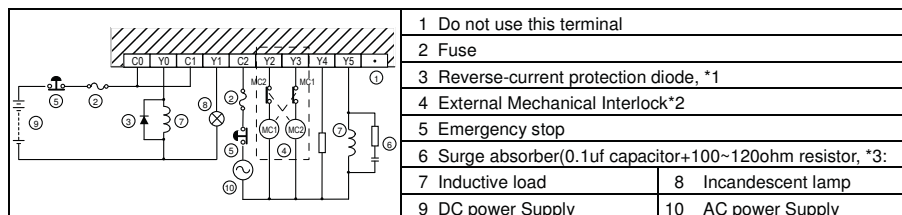

- 1 Do not use this terminal
- 2 Fuse
- 3 Reverse-current protection diode, *1
- 4 External Mechanical Interlock*2
- 5 Emergency stop
- 6 Surge absorber(0.1uf capacitor+100~120ohm resistor, *3:
- 7 Inductive load
- 8 Incandescent lamp
- 9 DC power Supply
- 10 AC power Supply

*1: This ELC does not have any internal protection circuitry on the relay outputs. For switching direct current on inductive loads, a reverse-current protection diode should be installed in parallel with the load. The relay contact life decreases significantly if this is not done.

The reverse-current protection diode needs to satisfy the following specifications.

- The diode is rated for maximum reverse voltage of 5~10 times the load voltage.
- The forward current is more that the load current

*2: Ensure all loads are applied to the same side of each ELC output, see above figure. Loads which should NEVER simultaneously operate(e.g. direction control of a motor), because of a critical safety situation, should not rely on the ELC's sequencing alone. Mechanical interlocks MUST be fitted to all critical safety circuits.

*3: This ELC does not have any internal protection circuitry on the relay output. For switching AC on inductive loads, a surge absorber (0.1uF + "100ohm to 120ohm") should be installed in parallel with the load. The relay contat life decreases significantly if this is not done. Besides protecting the internal circuitry of the ELC, a surge absorber decreases the noise emissions to the load.

■ The Transistor Output Circuit Wiring

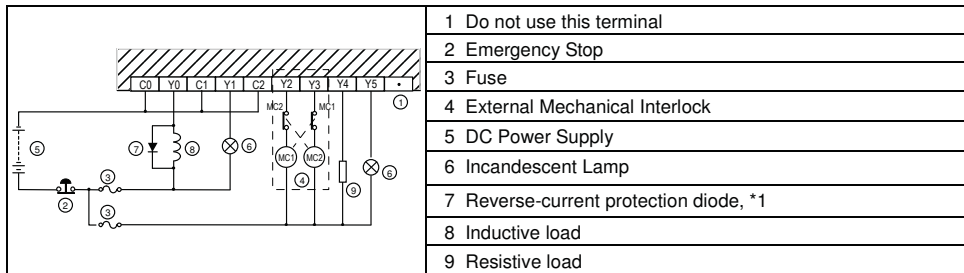

*1: Ensure all loads are applied to the same side of each ELC output, see above figure. Loads which should NEVER simutaneously operate (e.g. direction control of a motor), because of a critical safety situation, should not rely on the ELC's sequencing alone. Mechanical interlocks MUST be fitted to all critical safety circuits.

*2: Transistor outputs use internal zener diode(39V) as protection circuitry. When driving the inductive load with transistor output, a reverse-current protection diode can be installed in parallele with the load if necessary.

The reverse-current protection diode needs to satisfy the following specifications.

- The diode is rated for maximum reverse voltage of 5 to 10 times the load voltage.
- The forward current is more than the load current.

4 TRIAL RUN

4.1. Before Turning ON the Power

After wiring, be sure to check the items below before turning ON the power supply to the ELC.

Item	Description
Unit mounting status	<ul style="list-style-type: none"> - Does the unit type match the device list during the design stage? - Are all of the units firmly attached?
Power supply	<ul style="list-style-type: none"> - Is operating voltage supplied correctly? - Is the power supply cable properly connected? - Are both voltage and polarity connected correctly for each connection - Protection against excess current: when overloaded, output voltage lowers. Although the output voltage will return to normal when the load returns to normal, be careful as long overloads or short-circuits will cause deterioration or destruction of internal elements. - Attaching additional power supply units in parallel is not allowed! It may destroy internal elements and the load of the power supply.
Check input/Output terminals	<ul style="list-style-type: none"> - Does the wiring of connector and terminal match? - Is the operating voltage of I/O correct? - Are the connectors of I/O properly connected? - Is the wire size correct?

Note: These precautions concern the ELC-PS01/PS02 power supply unit specifically.

4.2. Turning the Power ON

After checking the items given on the section 7.1, perform the trial operation by adhering to the following procedure.

- Check "POWER" LED at the front of the ELC extension unit.
- Check "LV" LED at the front of the ELC extension unit.

4.3. Check Communication with ELC control unit

After Power on and ELC is completing initial setup. The total number of extensive input/output points will be stored in special data registers of D1142 and D1143.

Please check D1142 and D1143 to confirm the adding extension unit is connecting with control unit normally.

5 TROUBLESHOOTING

5.1. All LEDs are OFF

- Check the power supply wiring.
- Check if the power supplied to the ELC control units is in the range of the rating.
Be sure to check the fluctuation in the power supply.
- Disconnect the power supply wiring to the other devices if the power supplied to the ELC control unit is shared with them.
If the LEDs on the ELC control unit turn ON at this moment, the capacity of the power supply is not enough to control other devices as well. Prepare another power supply for other devices or increase the capacity of the power supply.

5.2. Diagnosing Input Malfunction

- Check the wiring of the input devices(input indicator LEDs are OFF)
 - Check that the power is properly supplied to the input terminals.
If the power is properly supplied to the input terminal, there is probably an abnormality in the ELC's input circuit. Please contact your dealer.
If the power is not properly supplied to the input terminal, there is probably an abnormality in the input device or input power supply. Check the input device and input power supply.
- Check the input condition (input indicator LEDs are ON)
 - Monitor the input condition using a programming tool.
If the input monitored is OFF, there is probably an abnormality in the ELC's input circuit. Please contact your dealer.
If the input monitored is ON, check the program again. Also, check the leakage current at the input devices (e.g., two-wire sensor) and check for the duplicated use of output or the program flow when a control instruction such as MC or CJ is used.
Check the settings of the I/O allocation.

5.3. Diagnosing Output Malfunction

- Check the wiring of the loads. (output indicator LEDs are ON)
 - Check if the power is properly supplied to the loads.
If the power is properly supplied to the load, there is probably an abnormality in the load. Check the load again. If the power is not supplied to the load, there is probably an abnormality in the ELC's output circuit. Please contact your dealer.
- Check of output condition (output indicator LEDs are OFF)
 - Monitor the output condition using a programming tool.
If the output monitored is turned ON, there is probably a duplicated output error.
 - Forcing ON the output using a programming tool.
If the output indicator LED is turned ON, go to input condition check.
If the output LED remains OFF, there is probably an abnormality in the ELC's output circuit. Please contact your dealer.