

Carlton®

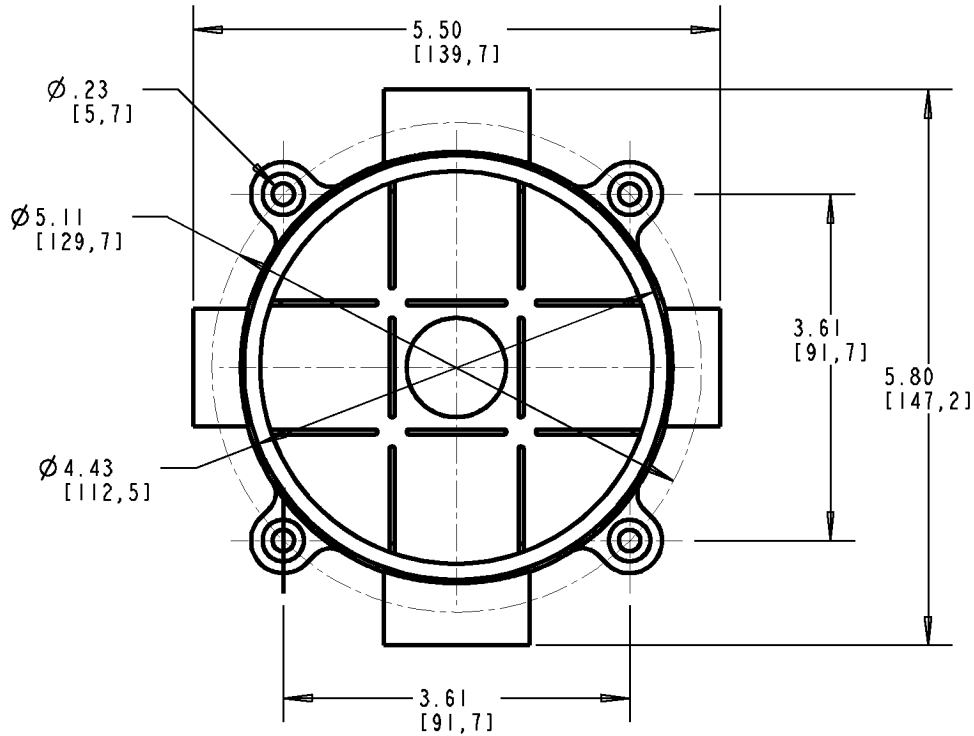

2 PORTS FOR
3/4" DIA.
CONDUIT 180°
APART

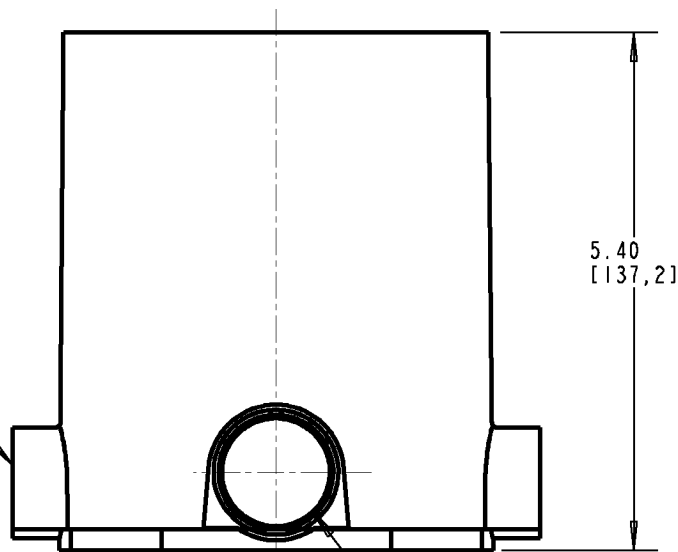

P/N
E971FB
E971FB-CAR
E971FBCL

INCLUDES:

- 1 - FLOOR BOX BASE
- 1 - DISPOSABLE POURING CAP
- 2 - 1"X3/4" REDUCER PLUGS
- 3 - 3/4"X1/2" REDUCER PLUGS

MAXIMUM INTERNAL VOLUME 90 CU. IN.
15.5 CU. IN. PER INCH OF DEPTH
MINIMUM CONCRETE DEPTH - 3"

GENERAL NOTES

- 1. ALL DIMENSIONS ARE FOR REFERENCE ONLY.
- 2. DIMENSIONS IN BRACKETS [] ARE IN METRIC UNITS.

REVISIONS

*** SEE ERN (****)
FOR APPROVAL SIGNATURES
& RELEASE DATE.
PROJECT NO: ****

Thomas & Betts
www.tnb.com

DESCRIPTION:

ROUND FLOOR BOX

ORIGINAL PROJECT NO / (ERN NO)

/ ()

SHEET NO:

1 OF 1

REV. NO:

E

DRAWING NO:

WSD-AC02471

Carlton®

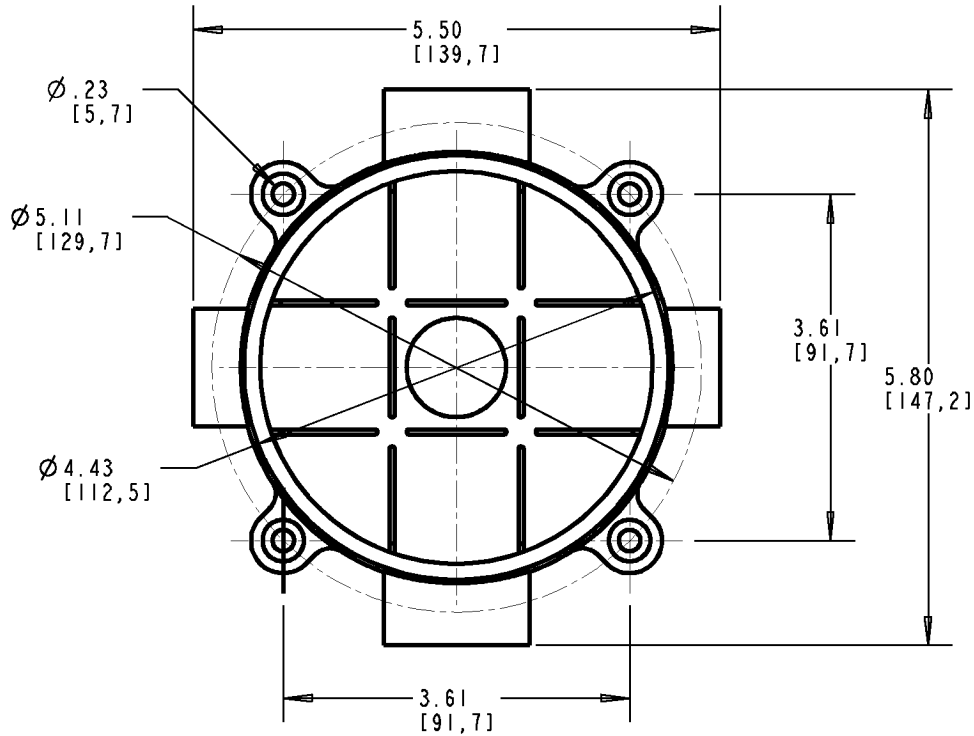

2 PORTS FOR
3/4" DIA.
CONDUIT 180°
APART

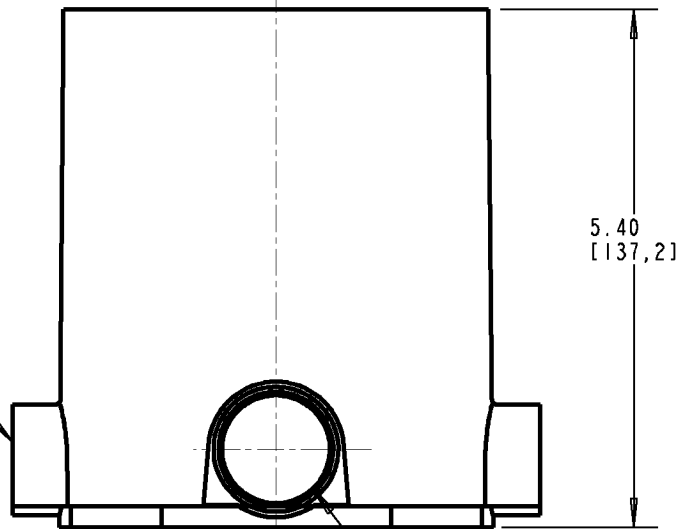

P/N
E971FB
E971FB-CAR
E971FBCL

INCLUDES:

- 1 - FLOOR BOX BASE
- 1 - DISPOSABLE POURING CAP
- 2 - 1"X3/4" REDUCER PLUGS
- 3 - 3/4"X1/2" REDUCER PLUGS

2 PORTS FOR 1" DIA.
CONDUIT 180° APART

MAXIMUM INTERNAL VOLUME 90 CU. IN.
15.5 CU. IN. PER INCH OF DEPTH
MINIMUM CONCRETE DEPTH - 3"

GENERAL NOTES

- 1. ALL DIMENSIONS ARE FOR REFERENCE ONLY.
- 2. DIMENSIONS IN BRACKETS [] ARE IN METRIC UNITS.

REVISIONS

*** SEE ERN (****)
FOR APPROVAL SIGNATURES
& RELEASE DATE.
PROJECT NO: ****

Thomas & Betts
www.tnb.com

DESCRIPTION:

ROUND FLOOR BOX

ORIGINAL PROJECT NO / (ERN NO)

/ ()

SHEET NO:

1 OF 1

REV. NO:

E

DRAWING NO:

WSD-AC02471