

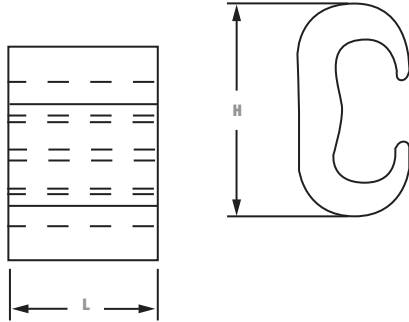

## C-Taps



Cat. No.	Main	Tap	Dimensions in. (mm)		Dies for TBM14M, 13100A or TBM151*	Crimps
			H	L		
CTP22	#6 sol.-#2 str.	#6 sol.-#2 str.**	1.16 (29.5)	0.75 (19.1)	HBKC	1
CTP202	#1 str.-2/0 str.		1.41 (35.8)			
CTP2020	#1 str.-2/0 str.	#1 str.-2/0 str.	1.54 (39.1)			
CTP25020	3/0 str.-250 kcmil	#6 sol.-2/0 AWG**	1.97 (50.0)		15G86R	
CTP250250		3/0 str.-250 kcmil	2.06 (52.3)			
CTP50020	300-500 kcmil	#6 sol.-2/0 AWG**	2.42 (61.5)	0.88 (22.4)	15G121R	2
CTP500250		3/0 str.-250 kcmil	2.67 (67.8)			
CTP500500†		300-500 kcmil	2.91 (73.9)			

\* Cat. No. 15500 adaptor required if using TBM151 and 155XX series Dies.  
 \*\* #6 AWG branch must be doubled.  
 † Must use TBM151 tool  
 Material: High-Conductivity Copper.

## Copper C-Crimps Wire Combinations\*\*

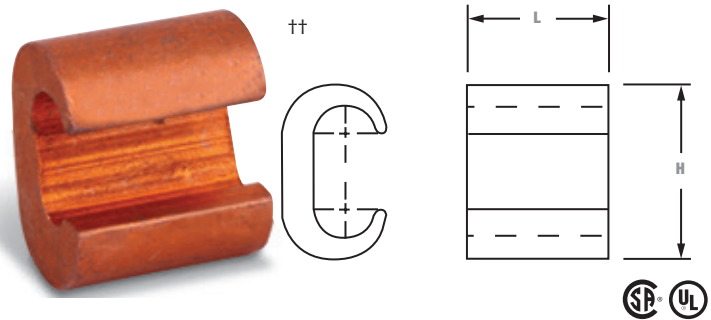
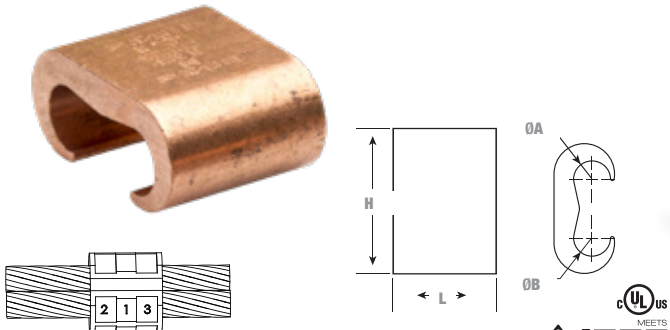

Figure 1 – Requires 3 crimps



Cat. No.	Ø A Cable	Ø B Cable	H (in.)	L (in.)	Crimps	Dies for Tools*
CTP22N	#6 sol.- #2 str.	#6 sol.- #2 str.	1-5/32	1-1/2	3	15534SS (Fig.1)
CTP202N	#1 str.- 2/0 str.	#6 sol.- #2 str.	1-13/32	1-1/2	3	15517SS (Fig.1)
CTP2020N	#1 str.- 2/0 str.	#1 str.- 2/0 str.	1-9/16	1-1/2	3	15517SS (Fig.1)
CTP25020N	3/0 str.- 250 kcmil	#1 str.- 2/0 str.	1-31/32	1-1/2	3	15506SS (Fig.1)
CTP250250N†	3/0 str.- 250 kcmil	3/0 str.- 250 kcmil	2-1/16	1-1/2	3	15506SS (Fig.1)
CTP500250N	300 - 500 kcmil	3/0 str.- 250 kcmil	2.72	2.5	5	15603SS
CTP50020N	300 - 500 kcmil	#6 sol.- 2/0 str.	2.42	2.5	5	15603SS
CTP500500N**	300 - 500 kcmil	300 - 500 kcmil	2.92	2.5	5	15G121N

\* These dies may be used with the TBM15CR-LI or TBM151 compression tools. Please note that the die adapter 15500-TB is required for use with these tools.

\*\*Can be used with 3/4 in. (17.3 mm) copper clad ground rod. The ground rod must be pre-crimped with die 15507SS to comply with IEEE 837-2014.

† Can be used with 5/8 in. (15.8 mm) copper clad ground rod. The ground rod must be pre-crimped with die 15526SS to comply with IEEE 837-2014.

Cat. No.	Run	Tap	Die Index	Manual Tool OD Series	Installing Die 14- and 15-Ton Tools	Dimensions in. (mm)	
						L	H
BC48	6 sol.-4 str.	8 sol.-8 str.	BG or 5/8	BY31	B58CS	0.64 (16.3)	0.56 (14.2)
BC46-BB		6 sol.-6 str.					0.75 (19.1)
BC44		4 sol.-4 str.					0.80 (20.3)
BC24	2 sol.-2 str.	8 sol.-4 str.	C	BY33	HBKC	0.75 (19.1)	0.98 (24.9)
BC22		2 sol.-2 str.					1.05 (26.7)
BC202	1/0 sol.-2/0 str.	8 sol.-2 str.	E or O	-	HO	0.94 (23.9)	1.31 (33.3)
BC2020-BB		1/0 str.-2/0 str.					1.34 (34.0)
BC402	3/0 str.-4/0 str.	6 sol.-2 str.	F or D3	-	HD	1.06 (26.9)	1.63 (41.4)
BC4020		1/0 sol.-2/0 str.					
BC4040		3/0 sol.-4/0 str.					

\*\*Do not meet IEEE 837.

## C-Taps

### Small Size

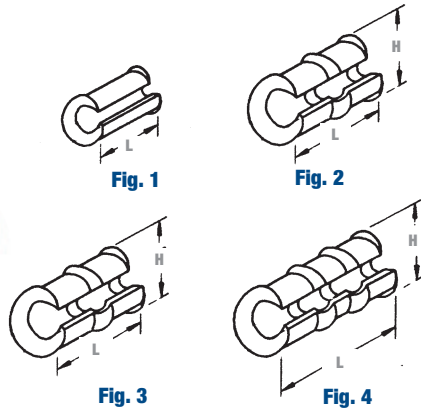

### Large Size for Certified to 600 V

- More economical than other taps and split bolts in terms of purchase, inventory, installation time, insulation and maintenance.
- Color-coded for easy matching with proper die
- Barely larger than conductor insulation once installed

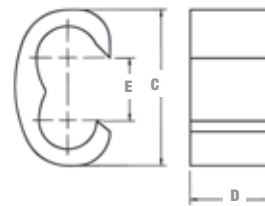

**Material:** High-Conductivity Wrought Copper  
**Finish:** Plain



Cat. No.	Code Wire Comb. Cir. Area Range		Die		Group 2	Group 3	Insulation Choice		Dimensions in. (mm)		Colour Code				
	Main	Branch	Group 1	Smart™ Tools			Adhesive	Shrink Tubing	L	H					
54705	12	14	6TON21SS	TBM6221	↑ Accommodates this range ↓	↑ Accommodates this entire range ↓	HS12-6		0.31	0.31	Red				
	14	16							(7.9)	(7.9)					
54710	10	10	6TON24SS	TBM6224					HS12-6		0.56	0.44	Blue		
	8	12									(14.2)	(11.2)			
54715	6	10, 12	6TON29SS	TBM6229							HS12-6		0.56	0.63	Grey
	8	8, 10, 12											(14.2)	(16.0)	
54720	4 or 5	6, 8, 10, 12	6TON33SS	TBM6233			HS12-6						1.16	0.69	Brown
	6	6, 8											(29.5)	(17.5)	
54725	3	6, 8, 10, 12***	6TON37SS	TBM6237					HS12-6				1.16	0.81	Green
	4 or 5	6, 5											(29.5)	(20.6)	
54730	2	6, 8, 10, 12	6TON42SS	TBM6242							HS6-1		1.16	0.84	Pink
	3	5											(29.5)	(21.3)	
	4	3													
54735	1	4, 5, 6, 8, 10, 12	6TON45SS	TBM6245	AC5X3		0.06	0.88					Black		
	2	4, 5					(1.5)	(22.4)							
	3	3, 4													
54740	1/0	4, 5, 6, 8, 10, 12	6TON50SS	TBM6250			HS4-30		1.69	0.97	Orange				
	1	3, 4							(42.9)	(24.6)					
	2	2, 3													
54745	2/0	3, 4, 5, 6, 8, 10, 12	6TON54SS	TBM6254	HS4-30				1.69	1.06	Purple				
	1/0	2, 3							(42.9)	(26.9)					
54750	3/0	2, 3, 4, 5, 6, 8, 10, 12	6TON62SS	TBM6262					TBM8-750C4550		1.69	1.19	Yellow		
	2/0	1, 2					(42.9)	(30.2)							
	1/0	1/0, 1													

Cat. No.	Wire Size		Dimensions in. (mm)			Installing Die		Die Code	No. of Crimps	Colour Code
	Main	Branch	C	D	E	Tool	Cat. No.			
54755	#1	#1	1.93	0.75	0.53	TBM14M	15512SS	76	1	Blue
	1/0	2/0-#3								
	2/0	1/0-#6								
	3/0	#1-#8								
	4/0									
54760	2/0	2/0-#1	1.43	0.75	0.59	TBM14M	15506SS	87H	2	Brown
	3/0	3/0-#3								
	4/0	4/0-#4								
	250 kcmil	#1-#8								
54765	2/0	2/0-#1	1.68	1.00	0.64	TBM14M	15505SS	99H	2	Pink
	3/0	3/0-#2								
	4/0	4/0-#4								
	250 kcmil	3/0-#6								
	300 kcmil	2/0-#8								
54770	4/0	4/0-2/0	1.68	1.00	0.68	TBM14M	15515SS	106H	2	Black
	250 kcmil	250-#1								
	300 kcmil	4/0-#4								
	350 kcmil	3/0-#6								
54775**	250 kcmil	250 kcmil	1.88	1.25	0.81	TBM14M	15504SS	115H	2	Yellow
	300 kcmil	300-3/0								
	350 kcmil	350-1/0								
	400 kcmil	300-#2								
	450 kcmil	250-#4								
500 kcmil	250-#6									
54780	350 kcmil	350-4/0	2.18	1.25	0.82	TBM15I	15603	125H	2	N/A
	400 kcmil	400-2/0								
	450 kcmil	450-#1								
	500 kcmil	500-#2								
54785	750 kcmil	4/0-#6	2.12	2.00	1.00	TBM15I	15603	125H	3	N/A
54790	750 kcmil	750-4/0	2.68	2.00	1.31	TBM15I	15603	125H	3	N/A

\*\*\* When using 3 AWG on main and 12 AWG on branch with Smart™ Tools and dies, 12 AWG wire must be doubled (hair-pinned) and placed on branch for crimping.  
 Group 1 = TBM6H, TBM62PCR-LI, TBM62CR-LI, TBM6UNICR-LI.  
 Group 2 = TBM45S, TBM41E (require 2 compressions within each crimp area).  
 Group 3 = TBM4/4S, TBM5S, TBM6S, TBM8/8S, TBM6H (require 1 compression within each crimp area).

UL approved for direct burial.  
 For covers see Section B.  
 Taps can be supplied tin-plated. Add suffix "TP" to any Cat. No. (i.e. 54725TP).  
 \* Cat. No. 15500TB adaptor required if using TBM15I and 155xx series dies.  
 \*\* #6 AWG branch must be doubled.  
 Tooling and Die Selector Chart see Section E.

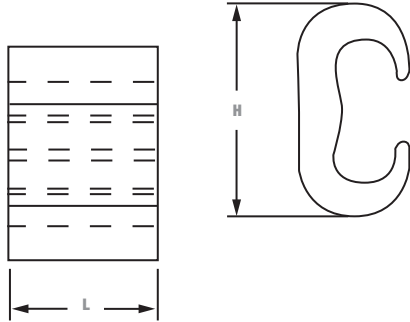

## C-Taps



Cat. No.	Main	Tap	Dimensions in. (mm)		Dies for TBM14M, 13100A or TBM151*	Crimps
			H	L		
CTP22	#6 sol.-#2 str.	#6 sol.-#2 str.**	1.16 (29.5)	0.75 (19.1)	HBKC	1
CTP202	#1 str.-2/0 str.		1.41 (35.8)			
CTP2020	#1 str.-2/0 str.	#1 str.-2/0 str.	1.54 (39.1)			
CTP25020	3/0 str.-250 kcmil	#6 sol.-2/0 AWG**	1.97 (50.0)			
CTP250250		3/0 str.-250 kcmil	2.06 (52.3)			
CTP50020	300-500 kcmil	#6 sol.-2/0 AWG**	2.42 (61.5)	0.88 (22.4)	15G121R	2
CTP500250		3/0 str.-250 kcmil	2.67 (67.8)			
CTP500500†		300-500 kcmil	300-500 kcmil	2.91 (73.9)		1.10 (27.9)

\* Cat. No. 15500 adaptor required if using TBM151 and 155XX series Dies.  
 \*\* #6 AWG branch must be doubled.  
 † Must use TBM151 tool  
 Material: High-Conductivity Copper.

## Copper C-Crimps Wire Combinations\*\*

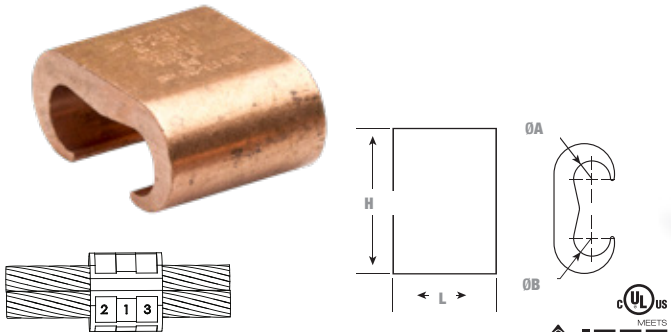
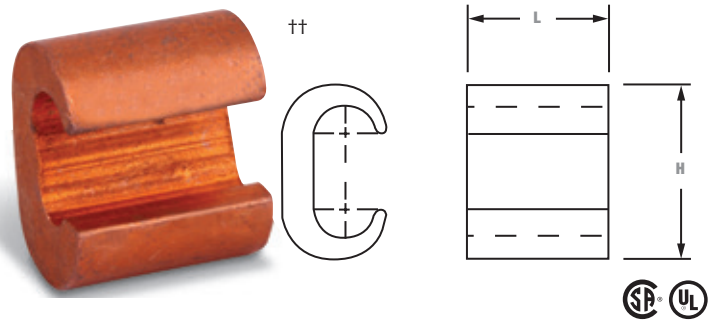

Figure 1 – Requires 3 crimps



Cat. No.	Ø A Cable	Ø B Cable	H (in.)	L (in.)	Crimps	Dies for Tools*
CTP22N	#6 sol.- #2 str.	#6 sol.- #2 str.	1-5/32	1-1/2	3	15534SS (Fig.1)
CTP202N	#1 str.- 2/0 str.	#6 sol.- #2 str.	1-13/32	1-1/2	3	15517SS (Fig.1)
CTP2020N	#1 str.- 2/0 str.	#1 str.- 2/0 str.	1-9/16	1-1/2	3	15517SS (Fig.1)
CTP25020N	3/0 str.- 250 kcmil	#1 str.- 2/0 str.	1-31/32	1-1/2	3	15506SS (Fig.1)
CTP250250N†	3/0 str.- 250 kcmil	3/0 str.- 250 kcmil	2-1/16	1-1/2	3	15506SS (Fig.1)
CTP500250N	300 - 500 kcmil	3/0 str.- 250 kcmil	2.72	2.5	5	15603SS
CTP50020N	300 - 500 kcmil	#6 sol.- 2/0 str.	2.42	2.5	5	15603SS
CTP500500N**	300 - 500 kcmil	300 - 500 kcmil	2.92	2.5	5	15G121N

\* These dies may be used with the TBM15CR-LI or TBM151 compression tools. Please note that the die adapter 15500-TB is required for use with these tools.

\*\*Can be used with 3/4 in. (17.3 mm) copper clad ground rod. The ground rod must be pre-crimped with die 15507SS to comply with IEEE 837-2014.

† Can be used with 5/8 in. (15.8 mm) copper clad ground rod. The ground rod must be pre-crimped with die 15526SS to comply with IEEE 837-2014.

Cat. No.	Run	Tap	Die Index	Manual Tool OD Series	Installing Die 14- and 15-Ton Tools	Dimensions in. (mm)	
						L	H
BC48	6 sol.-4 str.	8 sol.-8 str.	BG or 5/8	BY31	B58CS	0.64 (16.3)	0.56 (14.2)
BC46-BB		6 sol.-6 str.					0.75 (19.1)
BC44		4 sol.-4 str.					0.80 (20.3)
BC24	2 sol.-2 str.	8 sol.-4 str.	C	BY33	HBKC	0.75 (19.1)	0.98 (24.9)
BC22		2 sol.-2 str.					1.05 (26.7)
BC202	1/0 sol.-2/0 str.	8 sol.-2 str.	E or O	-	HO	0.94 (23.9)	1.31 (33.3)
BC2020-BB		1/0 str.-2/0 str.					1.34 (34.0)
BC402	3/0 str.-4/0 str.	6 sol.-2 str.	F or D3	-	HD	1.06 (26.9)	1.63 (41.4)
BC4020		1/0 sol.-2/0 str.					
BC4040		3/0 sol.-4/0 str.					

\*\*Do not meet IEEE 837.

## C-Taps

### Small Size

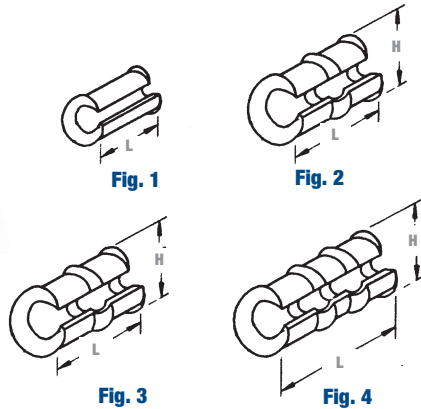

### Large Size for Certified to 600 V

- More economical than other taps and split bolts in terms of purchase, inventory, installation time, insulation and maintenance.
- Color-coded for easy matching with proper die
- Barely larger than conductor insulation once installed

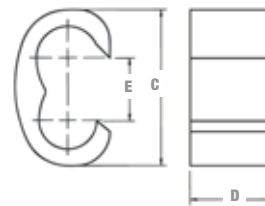

**Material:** High-Conductivity Wrought Copper  
**Finish:** Plain



Cat. No.	Code Wire Comb. Cir. Area Range		Die		Group 2	Group 3	Insulation Choice		Dimensions in. (mm)		Colour Code			
	Main	Branch	Group 1	Smart™ Tools			Adhesive	Shrink Tubing	L	H				
54705	12	14	6TON21SS	TBM6221	Accommodates this range	↑	HS12-6		0.31	0.31	Red			
	14	16							(7.9)	(7.9)	Blue			
54710	10	10	6TON24SS	TBM6224					↓	HS12-6			0.56	0.44
	8	12									(14.2)		(11.2)	
54715	6	10, 12	6TON29SS	TBM6229					↓	HS12-6		0.56	0.63	Grey
	8	8										(14.2)	(16.0)	
54720	4 or 5	8, 10, 12	6TON33SS	TBM6233			↓	HS12-6		1.16	0.69	Brown		
	6	6, 8								(29.5)	(17.5)			
54725	3	6, 8, 10, 12***	6TON37SS	TBM6237			↓	HS12-6		1.16	0.81	Green		
	4 or 5	6, 5								(29.5)	(20.6)			
54730	2	6, 8, 10, 12	6TON42SS	TBM6242			↓	HS6-1		1.16	0.84	Pink		
	3	5								(29.5)	(21.3)			
	4	3												
54735	1	4, 5, 6, 8, 10, 12	6TON45SS	TBM6245	↓	HS6-1		0.06	0.88	Black				
	2	4, 5						(1.5)	(22.4)					
	3	3, 4												
54740	1/0	4, 5, 6, 8, 10, 12	6TON50SS	TBM6250	↓	HS6-1		1.69	0.97	Orange				
	1	3, 4						(42.9)	(24.6)					
	2	2, 3												
54745	2/0	3, 4, 5, 6, 8, 10, 12	6TON54SS	TBM6254	↓	HS4-30		1.69	1.06	Purple				
	1/0	2, 3						(42.9)	(26.9)					
54750	3/0	2, 3, 4, 5, 6, 8, 10, 12	6TON62SS	TBM6262	↓	HS4-30		1.69	1.19	Yellow				
	2/0	1, 2						(42.9)	(30.2)					
	1/0	1/0, 1												

Cat. No.	Wire Size		Dimensions in. (mm)			Installing Die		Die Code	No. of Crimps	Colour Code
	Main	Branch	C	D	E	Tool	Cat. No.			
54755	#1	#1	1.93	0.75	0.53	TBM14M	15512SS	76	1	Blue
	1/0	2/0-#3								
	2/0	1/0-#6								
	3/0	#1-#8								
	4/0									
54760	2/0	2/0-#1	1.43	0.75	0.59	TBM14M	15506SS	87H	2	Brown
	3/0	3/0-#3								
	4/0	4/0-#4								
	250 kcmil	#1-#8								
54765	2/0	2/0-#1	1.68	1.00	0.64	TBM14M	15505SS	99H	2	Pink
	3/0	3/0-#2								
	4/0	4/0-#4								
	250 kcmil	3/0-#6								
	300 kcmil	2/0-#8								
54770	4/0	4/0-2/0	1.68	1.00	0.68	TBM14M	15515SS	106H	2	Black
	250 kcmil	250-#1								
	300 kcmil	4/0-#4								
	350 kcmil	3/0-#6								
54775**	250 kcmil	250 kcmil	1.88	1.25	0.81	TBM14M	15504SS	115H	2	Yellow
	300 kcmil	300-3/0								
	350 kcmil	350-1/0								
	400 kcmil	300-#2								
	450 kcmil	250-#4								
500 kcmil	250-#6									
54780	350 kcmil	350-4/0	2.18	1.25	0.82	TBM15I	15603	125H	2	N/A
	400 kcmil	400-2/0								
	450 kcmil	450-#1								
	500 kcmil	500-#2								
54785	750 kcmil	4/0-#6	2.12	2.00	1.00	TBM15I	15603	125H	3	N/A
54790	750 kcmil	750-4/0	2.68	2.00	1.31	TBM15I	15603	125H	3	N/A

\*\*\* When using 3 AWG on main and 12 AWG on branch with Smart™ Tools and dies, 12 AWG wire must be doubled (hair-pinned) and placed on branch for crimping.  
 Group 1 = TBM6H, TBM62PCR-LI, TBM62CR-LI, TBM6UNICR-LI.  
 Group 2 = TBM45S, TBM41E (require 2 compressions within each crimp area).  
 Group 3 = TBM4/4S, TBM5S, TBM6S, TBM8/8S, TBM6H (require 1 compression within each crimp area).

UL approved for direct burial.  
 For covers see Section B.  
 Taps can be supplied tin-plated. Add suffix "TP" to any Cat. No. (i.e. 54725TP).  
 \* Cat. No. 15500TB adaptor required if using TBM15I and 155xx series dies.  
 \*\* #6 AWG branch must be doubled.  
 Tooling and Die Selector Chart see Section E.