

5" NEMA VE 1 Loading Depth 6" Side Rail Height

Straight Section Part Numbering

Example: ^{Prefix} **26 A 09 - 24 - 144**

Series	Material	*Type	*Width	Length
● 26	● A = Aluminum	Ladder-	● 06 = 6"	● ① 144 = 12 ft. 26
● 36		● 06 = 6" rung spacing	● 09 = 9"	● ② 120 = 10 ft.
● 46		● 09 = 9" rung spacing	● 12 = 12"	● ① 240 = 20 ft. 36
● H46		● 12 = 12" rung spacing	● 18 = 18"	● ② 144 = 12 ft.
● 56			● 24 = 24"	● ① 240 = 20 ft. 46
			● 30 = 30"	● ② 288 = 24 ft.
			● 36 = 36"	● ① 240 = 20 ft. H46
			42 = 42"†	● ② 300 = 25 ft.
			48 = 48"†	● ① 240 = 20 ft. 57
				● ② 288 = 24 ft.
				● ② 300 = 25 ft.
				● ② 360 = 30 ft.

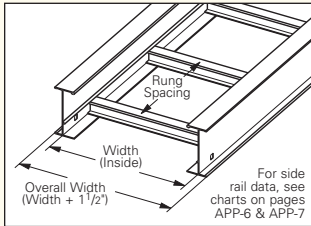

Trough-
6" thru 36" wide

- VT = Ventilated Trough
- ST = Non-Ventilated Trough

† For 56A only

① Primary Length.
② Secondary Length.

See page C-23 for explanation of lengths.

See page APP-1 for additional rung options. *Special sizes available.

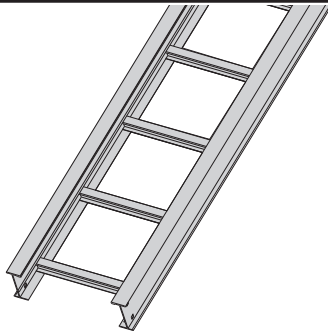

Ladder Type
(Specify Rung Spacing)

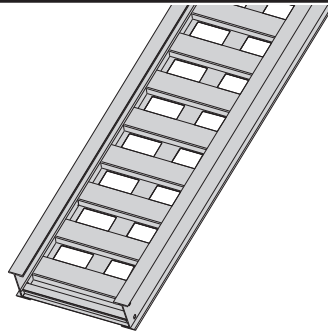

Ventilated Trough

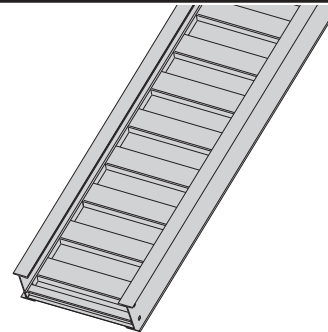

Non-Ventilated Trough

● Green = Fastest shipped items ● Black = Normal lead-time items ● Red = Normally long lead-time items

All dimensions in parentheses are millimeters unless otherwise specified.

Series 2, 3, 4, & 5 Aluminum - Straight Sections

5" NEMA VE 1 Loading Depth 6" Side Rail Height

Values are based on simple beam tests per NEMA VE 1 on 36" wide cable tray with rungs spaced on 12" centers. Cable trays will support, without collapse, a 200 lb. (90.7 kg) concentrated load over and above published loads. Published load safety factor is 1.5. To convert 1.5 safety factor to 2.0, multiply the published load by 0.75. To obtain mid-span deflection, multiply a load by the deflection multiplier. Cable tray must be supported on spans shorter than or equal to the length of the cable tray being installed.

Individual rungs will support without collapse a 200 lb. (90.7 kg) concentrated load applied at the mid-span of the rung, over and above the NEMA rated cable load with a 1.5 safety factor for highlighted NEMA spans and loads.

B-Line Series	Side Rail Dimensions	NEMA, CSA & UL Classifications	Span ft	Load lbs/ft	Deflection Multiplier	Design Factors for Two Rails	Span meters	Load kg/m	Deflection Multiplier	Design Factors for Two Rails
26		NEMA: 20A, 16B CSA: 67 kg/m 6.0m D-6m UL Cross-Sectional Area: 1.00 in ²	10	204	0.0028	Area = 1.41 in ² Sx = 2.53 in ³ Ix = 7.915 in ⁴	3.0	304	0.049	Area = 9.10 cm ² Sx = 41.46 cm ³ Ix = 329.45 cm ⁴
			12	142	0.006		3.7	211	0.101	
			14	104	0.011		4.3	155	0.186	
			16	80	0.019		4.9	119	0.318	
			18	63	0.030		5.5	94	0.509	
			20	51	0.045		6.1	76	0.776	

When trays are used in continuous spans, the deflection of the tray is reduced by as much as 50%. Design factors: Ix = Moment of Inertia, Sx = Section Modulus.

B-Line Series	Side Rail Dimensions	NEMA, CSA & UL Classifications	Span ft	Load lbs/ft	Deflection Multiplier	Design Factors for Two Rails	Span meters	Load kg/m	Deflection Multiplier	Design Factors for Two Rails
36		NEMA: 20B, 16C CSA: 112 kg/m 6.0m E-6m UL Cross-Sectional Area: 1.50 in ²	12	233	0.0043	Area = 1.81 in ² Sx = 3.36 in ³ Ix = 10.85 in ⁴	3.7	347	0.073	Area = 11.68 cm ² Sx = 55.06 cm ³ Ix = 451.61 cm ⁴
			14	171	0.008		4.3	255	0.136	
			16	131	0.014		4.9	195	0.232	
			18	104	0.022		5.5	154	0.372	
			20	84	0.033		6.1	125	0.566	
			22	69	0.049		6.7	103	0.829	

When trays are used in continuous spans, the deflection of the tray is reduced by as much as 50%. Design factors: Ix = Moment of Inertia, Sx = Section Modulus.

B-Line Series	Side Rail Dimensions	NEMA, CSA & UL Classifications	Span ft	Load lbs/ft	Deflection Multiplier	Design Factors for Two Rails	Span meters	Load kg/m	Deflection Multiplier	Design Factors for Two Rails
46		NEMA: 20C CSA: 168 kg/m 6.1m E-6m UL Cross-Sectional Area: 1.50 in ²	14	210	0.0071	Area = 2.06 in ² Sx = 3.59 in ³ Ix = 12.18 in ⁴	4.3	313	0.121	Area = 13.29 cm ² Sx = 58.83 cm ³ Ix = 506.97 cm ⁴
			16	161	0.012		4.9	239	0.207	
			18	127	0.019		5.5	189	0.331	
			20	103	0.030		6.1	153	0.505	
			22	85	0.043		6.7	127	0.739	
			24	72	0.061		7.3	106	1.046	

When trays are used in continuous spans, the deflection of the tray is reduced by as much as 50%. Design factors: Ix = Moment of Inertia, Sx = Section Modulus.

B-Line Series	Side Rail Dimensions	NEMA, CSA & UL Classifications	Span ft	Load lbs/ft	Deflection Multiplier	Design Factors for Two Rails	Span meters	Load kg/m	Deflection Multiplier	Design Factors for Two Rails
H46		NEMA: 20C+ CSA: 131 kg/m 7.6m E-6m UL Cross-Sectional Area: 2.00 in ²	16	261	0.0085	Area = 2.95 in ² Sx = 5.33 in ³ Ix = 17.30 in ⁴	4.9	388	0.145	Area = 19.03 cm ² Sx = 87.34 cm ³ Ix = 720.08 cm ⁴
			18	206	0.014		5.5	307	0.233	
			20	167	0.021		6.1	248	0.355	
			22	138	0.030		6.7	205	0.520	
			24	116	0.043		7.3	173	0.737	
			25	88	0.051		7.6	131	0.867	

When trays are used in continuous spans, the deflection of the tray is reduced by as much as 50%. Design factors: Ix = Moment of Inertia, Sx = Section Modulus.

B-Line Series	Side Rail Dimensions	NEMA, CSA & UL Classifications	Span ft	Load lbs/ft	Deflection Multiplier	Design Factors for Two Rails	Span meters	Load kg/m	Deflection Multiplier	Design Factors for Two Rails
56		NEMA: 20C+ CSA: 112 kg/m 9.1m E-6m UL Cross-Sectional Area: 2.00 in ²	20	169	0.016	Area = 3.63 in ² Sx = 6.12 in ³ Ix = 22.63 in ⁴	6.1	251	0.272	Area = 23.42 cm ² Sx = 100.29 cm ³ Ix = 941.86 cm ⁴
			22	139	0.023		6.7	208	0.398	
			24	117	0.033		7.3	174	0.563	
			26	100	0.045		7.9	149	0.776	
			28	86	0.061		8.5	128	1.043	
			30	75	0.081		9.1	112	1.375	

When trays are used in continuous spans, the deflection of the tray is reduced by as much as 50%. Design factors: Ix = Moment of Inertia, Sx = Section Modulus.

All dimensions in parentheses are millimeters unless otherwise specified.

5" NEMA VE 1 Loading Depth 6" Side Rail Height

Straight Section Part Numbering

Example: ^{Prefix} **26 A 09 - 24 - 144**

Series

- 26
- 36
- 46
- H46
- 56

Material

- A = Aluminum

*Type

Ladder-

- 06 = 6" rung spacing
- 09 = 9" rung spacing
- 12 = 12" rung spacing

*Width

- 06 = 6"
- 09 = 9"
- 12 = 12"
- 18 = 18"
- 24 = 24"
- 30 = 30"
- 36 = 36"
- 42 = 42"†
- 48 = 48"†

Length

- ① 144 = 12 ft. 26
- ② 120 = 10 ft.
- ① 240 = 20 ft. 36
- ② 144 = 12 ft.
- ① 240 = 20 ft. 46
- ② 288 = 24 ft.
- ① 240 = 20 ft. H46
- ② 300 = 25 ft.
- ① 240 = 20 ft. 57
- ② 288 = 24 ft.
- ② 300 = 25 ft.
- ② 360 = 30 ft.

† For 56A only

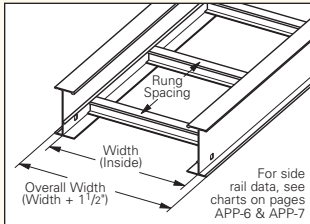

Trough-

6" thru 36" wide

- VT = Ventilated Trough
- ST = Non-Ventilated Trough

① Primary Length.
② Secondary Length.

See page C-23 for explanation of lengths.

See page APP-1 for additional rung options. *Special sizes available.

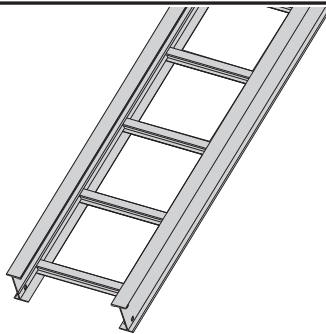

Ladder Type
(Specify Rung Spacing)

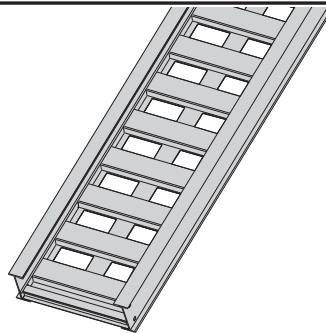

Ventilated Trough

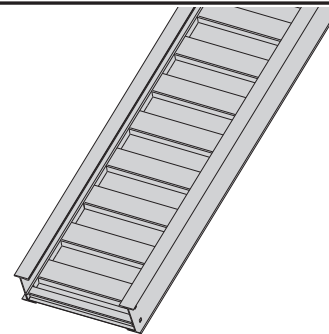

Non-Ventilated Trough

● Green = Fastest shipped items ● Black = Normal lead-time items ● Red = Normally long lead-time items

All dimensions in parentheses are millimeters unless otherwise specified.

Series 2, 3, 4, & 5 Aluminum - Straight Sections

5" NEMA VE 1 Loading Depth 6" Side Rail Height

Values are based on simple beam tests per NEMA VE 1 on 36" wide cable tray with rungs spaced on 12" centers. Cable trays will support, without collapse, a 200 lb. (90.7 kg) concentrated load over and above published loads. Published load safety factor is 1.5. To convert 1.5 safety factor to 2.0, multiply the published load by 0.75. To obtain mid-span deflection, multiply a load by the deflection multiplier. Cable tray must be supported on spans shorter than or equal to the length of the cable tray being installed.

Individual rungs will support without collapse a 200 lb. (90.7 kg) concentrated load applied at the mid-span of the rung, over and above the NEMA rated cable load with a 1.5 safety factor for highlighted NEMA spans and loads.

B-Line Series	Side Rail Dimensions	NEMA, CSA & UL Classifications	Span ft	Load lbs/ft	Deflection Multiplier	Design Factors for Two Rails	Span meters	Load kg/m	Deflection Multiplier	Design Factors for Two Rails
26		NEMA: 20A, 16B CSA: 67 kg/m 6.0m D-6m UL Cross-Sectional Area: 1.00 in ²	10	204	0.0028	Area = 1.41 in ² Sx = 2.53 in ³ Ix = 7.915 in ⁴	3.0	304	0.049	Area = 9.10 cm ² Sx = 41.46 cm ³ Ix = 329.45 cm ⁴
			12	142	0.006		3.7	211	0.101	
			14	104	0.011		4.3	155	0.186	
			16	80	0.019		4.9	119	0.318	
			18	63	0.030		5.5	94	0.509	
			20	51	0.045		6.1	76	0.776	

When trays are used in continuous spans, the deflection of the tray is reduced by as much as 50%. Design factors: Ix = Moment of Inertia, Sx = Section Modulus.

B-Line Series	Side Rail Dimensions	NEMA, CSA & UL Classifications	Span ft	Load lbs/ft	Deflection Multiplier	Design Factors for Two Rails	Span meters	Load kg/m	Deflection Multiplier	Design Factors for Two Rails
36		NEMA: 20B, 16C CSA: 112 kg/m 6.0m E-6m UL Cross-Sectional Area: 1.50 in ²	12	233	0.0043	Area = 1.81 in ² Sx = 3.36 in ³ Ix = 10.85 in ⁴	3.7	347	0.073	Area = 11.68 cm ² Sx = 55.06 cm ³ Ix = 451.61 cm ⁴
			14	171	0.008		4.3	255	0.136	
			16	131	0.014		4.9	195	0.232	
			18	104	0.022		5.5	154	0.372	
			20	84	0.033		6.1	125	0.566	
			22	69	0.049		6.7	103	0.829	

When trays are used in continuous spans, the deflection of the tray is reduced by as much as 50%. Design factors: Ix = Moment of Inertia, Sx = Section Modulus.

B-Line Series	Side Rail Dimensions	NEMA, CSA & UL Classifications	Span ft	Load lbs/ft	Deflection Multiplier	Design Factors for Two Rails	Span meters	Load kg/m	Deflection Multiplier	Design Factors for Two Rails
46		NEMA: 20C CSA: 168 kg/m 6.1m E-6m UL Cross-Sectional Area: 1.50 in ²	14	210	0.0071	Area = 2.06 in ² Sx = 3.59 in ³ Ix = 12.18 in ⁴	4.3	313	0.121	Area = 13.29 cm ² Sx = 58.83 cm ³ Ix = 506.97 cm ⁴
			16	161	0.012		4.9	239	0.207	
			18	127	0.019		5.5	189	0.331	
			20	103	0.030		6.1	153	0.505	
			22	85	0.043		6.7	127	0.739	
			24	72	0.061		7.3	106	1.046	

When trays are used in continuous spans, the deflection of the tray is reduced by as much as 50%. Design factors: Ix = Moment of Inertia, Sx = Section Modulus.

B-Line Series	Side Rail Dimensions	NEMA, CSA & UL Classifications	Span ft	Load lbs/ft	Deflection Multiplier	Design Factors for Two Rails	Span meters	Load kg/m	Deflection Multiplier	Design Factors for Two Rails
H46		NEMA: 20C+ CSA: 131 kg/m 7.6m E-6m UL Cross-Sectional Area: 2.00 in ²	16	261	0.0085	Area = 2.95 in ² Sx = 5.33 in ³ Ix = 17.30 in ⁴	4.9	388	0.145	Area = 19.03 cm ² Sx = 87.34 cm ³ Ix = 720.08 cm ⁴
			18	206	0.014		5.5	307	0.233	
			20	167	0.021		6.1	248	0.355	
			22	138	0.030		6.7	205	0.520	
			24	116	0.043		7.3	173	0.737	
			25	88	0.051		7.6	131	0.867	

When trays are used in continuous spans, the deflection of the tray is reduced by as much as 50%. Design factors: Ix = Moment of Inertia, Sx = Section Modulus.

B-Line Series	Side Rail Dimensions	NEMA, CSA & UL Classifications	Span ft	Load lbs/ft	Deflection Multiplier	Design Factors for Two Rails	Span meters	Load kg/m	Deflection Multiplier	Design Factors for Two Rails
56		NEMA: 20C+ CSA: 112 kg/m 9.1m E-6m UL Cross-Sectional Area: 2.00 in ²	20	169	0.016	Area = 3.63 in ² Sx = 6.12 in ³ Ix = 22.63 in ⁴	6.1	251	0.272	Area = 23.42 cm ² Sx = 100.29 cm ³ Ix = 941.86 cm ⁴
			22	139	0.023		6.7	208	0.398	
			24	117	0.033		7.3	174	0.563	
			26	100	0.045		7.9	149	0.776	
			28	86	0.061		8.5	128	1.043	
			30	75	0.081		9.1	112	1.375	

When trays are used in continuous spans, the deflection of the tray is reduced by as much as 50%. Design factors: Ix = Moment of Inertia, Sx = Section Modulus.

All dimensions in parentheses are millimeters unless otherwise specified.