



SERVICE PARTS LIST

BULLETIN NO.
54-40-2630

SPECIFY CATALOG NO. AND SERIAL NO. WHEN ORDERING PARTS		REVISED BULLETIN	DATE
18 Volt Circular Saw			Sept. 2008
CATALOG NO.	2630-20	STARTING SERIAL NO.	B57A
			WIRING INSTRUCTION SEE REVERSE SIDE

EXAMPLE:
00 0 Component Parts (Small #)
Are Included When Ordering
The Assembly (Large #).

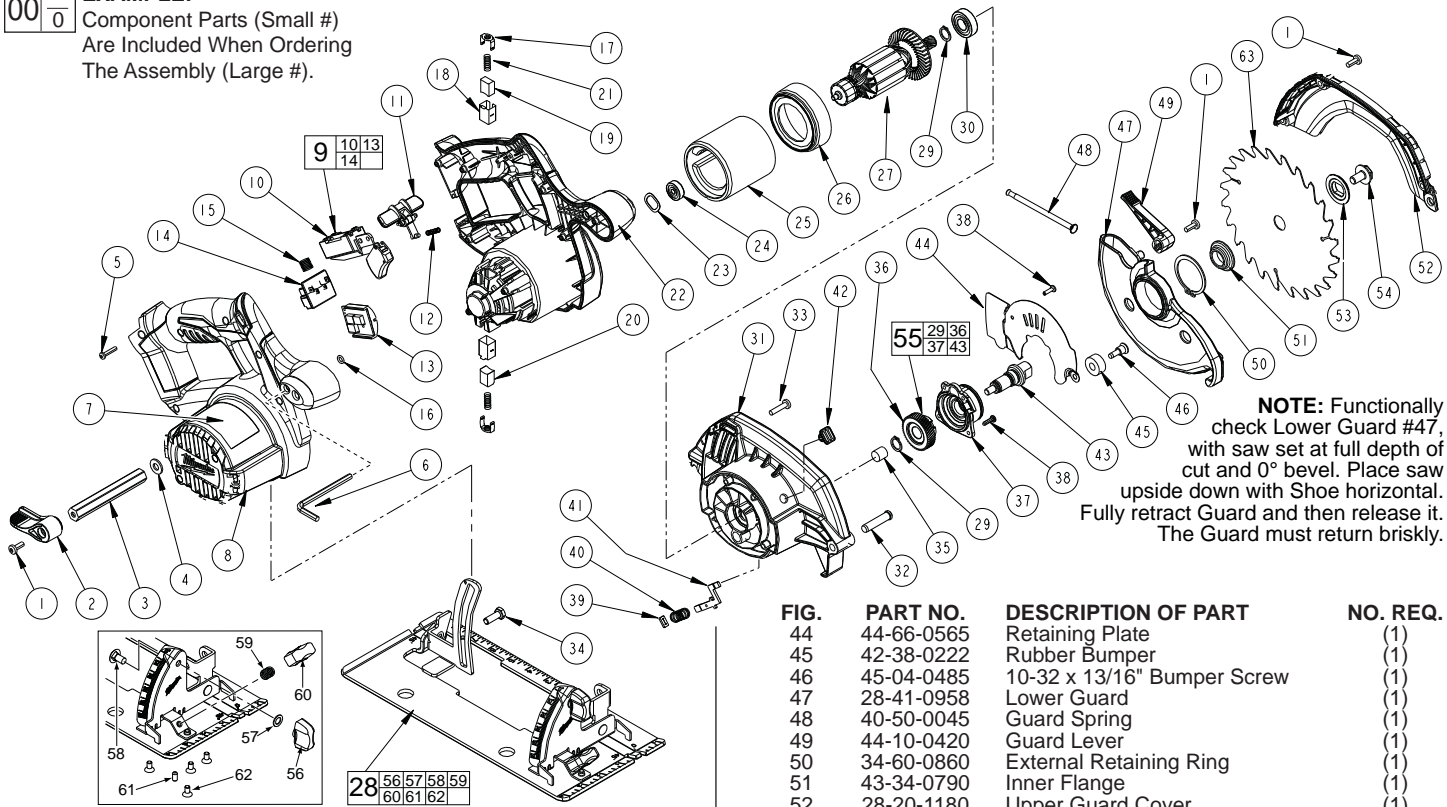

NOTE: Functionally check Lower Guard #47, with saw set at full depth of cut and 0° bevel. Place saw upside down with Shoe horizontal. Fully retract Guard and then release it. The Guard must return briskly.

FIG.	PART NO.	DESCRIPTION OF PART	NO. REQ.
1	06-82-5314	10-24 x 1/2" Pan Hd. Tapt. T-25 Screw	(5)
2	44-10-0430	Depth Lever	(1)
3	45-08-0395	Depth Shaft	(1)
4	45-88-1515	Flat Washer	(1)
5	06-82-7470	6 x 11/16" Pan Hd. Plast. T-15 Screw	(9)
6	49-96-0080	3/16" Hex Key	(1)
7	12-20-1355	Service Nameplate Kit	(1)
8	31-44-1972	Right Handle Half	(1)
9	23-66-1001	Switch Assembly	(1)
10	-----	Switch	(1)
11	42-42-1035	Switch Lock-Out	(1)
12	40-50-0350	Switch Lock-Out Spring	(1)
13	-----	FET Module Assembly	(1)
14	-----	Connector Block	(1)
15	40-50-1090	Compression Spring	(1)
16	34-40-4480	O-Ring	(1)
17	22-32-0420	Brush Spring Clip	(2)
18	22-20-0425	Brush Tube	(2)
19	22-18-1121	Brush Assembly - Red	(1)
20	22-18-1126	Brush Assembly - Black	(1)
21	40-50-8745	Brush Spring	(2)
22	31-44-1977	Left Handle Half	(1)
23	45-88-5615	Wave Spring Washer	(1)
24	02-04-5130	Ball Bearing	(1)
25	18-01-2000	Service Field	(1)
26	31-05-0350	Baffle	(1)
27	16-01-2111	Service Armature	(1)
28	14-74-0311	Shoe Assembly	(1)
29	34-60-0920	External Retaining Ring	(2)
30	02-04-1212	Ball Bearing	(1)
31	28-14-0749	Gearcase	(1)
32	44-60-0740	Pivot Pin	(1)
33	06-82-7475	6 x 7/8" Pan Hd. Plast. T-15 Screw	(4)
34	06-75-5860	1/4-20 x 3/4" Hex Hd. Screw	(1)
35	02-50-1640	Needle Bearing	(1)
36	32-75-1370	Spindle Gear	(1)
37	31-15-0601	Gearcase Cover Assembly	(1)
38	06-82-5285	6-32 x 1/2" Pan Hd. Tapt. T-15 Screw	(5)
39	45-06-0720	Felt Seal	(1)
40	40-50-8040	Spindle Lock Spring	(1)
41	44-20-0651	Spindle Lock	(1)
42	42-42-1030	Spindle Lock Button	(1)
43	38-50-1160	Spindle	(1)

FIG.	PART NO.	DESCRIPTION OF PART	NO. REQ.
44	44-66-0565	Retaining Plate	(1)
45	42-38-0222	Rubber Bumper	(1)
46	45-04-0485	10-32 x 13/16" Bumper Screw	(1)
47	28-41-0958	Lower Guard	(1)
48	40-50-0045	Guard Spring	(1)
49	44-10-0420	Guard Lever	(1)
50	34-60-0860	External Retaining Ring	(1)
51	43-34-0790	Inner Flange	(1)
52	28-20-1180	Upper Guard Cover	(1)
53	43-34-0795	Outer Flange	(1)
54	06-75-1010	Left Hand Blade Screw	(1)
55	14-46-2570	Spindle and Gear Assembly	(1)
56	43-98-0730	Bevel Adjustment Knob	(1)
57	45-88-1560	Washer	(1)
58	06-10-0660	1/4-20 x 1/2" Short Neck Carriage Bolt	(1)
59	40-50-0650	Spring	(1)
60	43-98-0720	Rip Fence Knob	(1)
61	06-83-1600	10-32 x 3/8" Set Screw	(1)
62	06-82-9605	10-32 x 3/8" CSK Machine T-25 Screw	(4)
63	-----	6-1/2" Blade	(1)
	10-15-0500	Warning Label (Not Shown)	(1)
	49-22-1001	Rip Fence (Not Shown)	(1)
	48-55-3500	Contractors Bag (Not Shown)	(1)

FIG. NOTE:
30 Orient the Ball Bearing so that the seal faces the fan and the open side faces the Gearcase.
35 Press Needle Bearing flush to .015 sub-flush in Gearcase.
41 Functionally check Spindle Lock. Spindle Lock must return briskly when released from engagement in gear.
50 Position Retaining Ring with rounded edge facing Lower Guard.
10,11 Functionally check Switch Lock-Out by attempting to turn on tool by applying a reasonable amount of force, up to 8 lbs., to the switch trigger. The tool must not turn on. Release trigger. Actuate the lock-out lever and apply a reasonable amount of force to the switch trigger. The tool must turn on. While the trigger is still in the "ON" position, release the lock-out. Release the trigger. The tool must stop and the lock-out lever must again prevent the actuation of the Switch. Repeat the switch check two more times.

FIG. LUBRICATION:
31 Apply 3.0 grams of "Y" grease, No. 49-08-5270 to gear bore of Gearcase. The grease should be directed toward the pinion end of the armature.

Apply a light film of lubricant to the bearing bore of the Gearcase before assembling the armature/bearing.

AS AN AID TO REASSEMBLY, TAKE NOTICE OF WIRE ROUTING AND POSITION IN WIRE GUIDES AND TRAPS WHILE DISMANTLING TOOL.

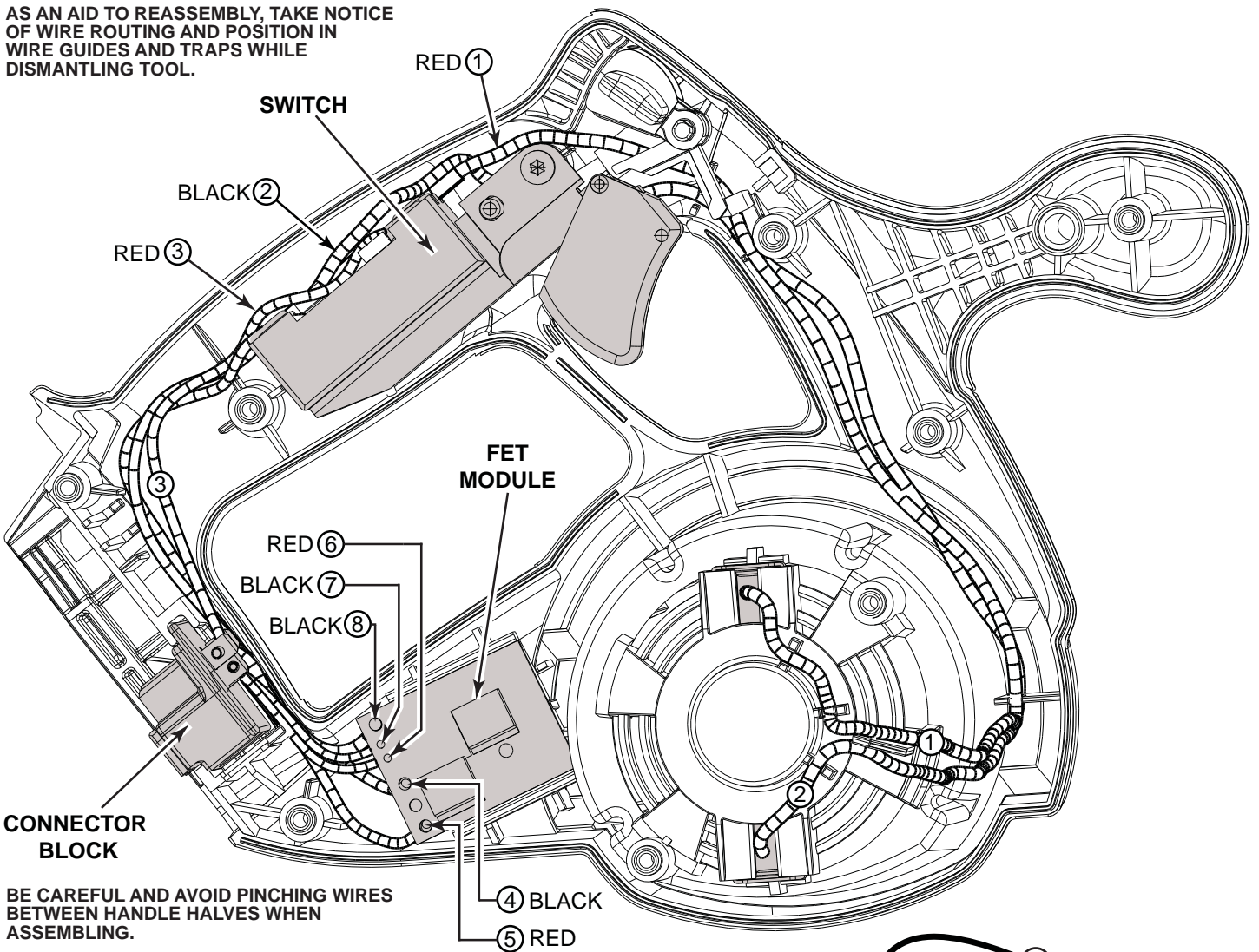

BE CAREFUL AND AVOID PINCHING WIRES BETWEEN HANDLE HALVES WHEN ASSEMBLING.

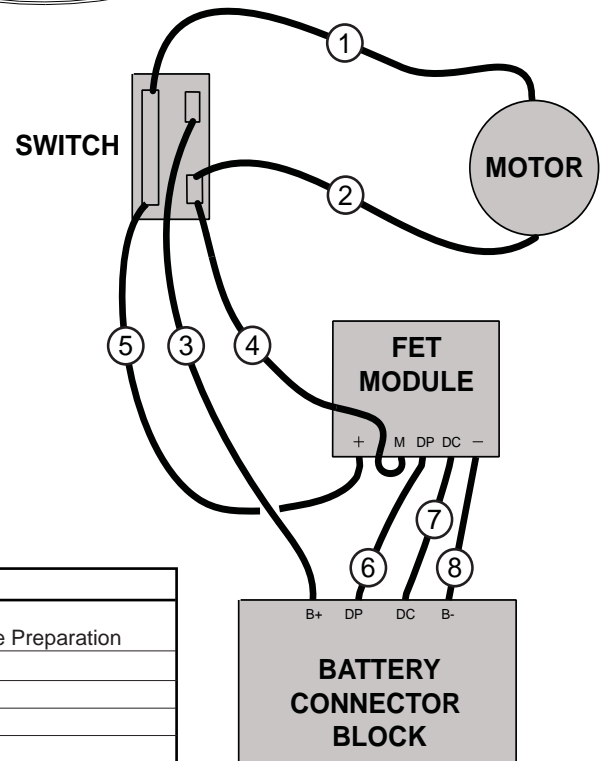

WIRING SPECIFICATIONS

Wire No.	Wire Color	Origin or Gauge	Length	Terminals, Connectors and 1 or 2 End Wire Preparation
1	Red	22-18-1121	-----	Carbon Brush Assembly - Top.
2	Black	22-18-1126	-----	Carbon Brush Assembly - Bottom.
3	Red	23-66-1001	-----	Component of the *Switch Assembly.
4	Black	23-66-1001	-----	Component of the *Switch Assembly.
5	RED	23-66-1001	-----	Component of the *Switch Assembly.
6	Red	23-66-1001	-----	Component of the *Switch Assembly.
7	Black	23-66-1001	-----	Component of the *Switch Assembly.
8	Black	23-66-1001	-----	Component of the *Switch Assembly.

* Switch Assy. No. 23-66-1001 consists of Switch, Connector Block and FET Module & associated wires.