

CLKT C-Range Infrared Window for outdoor applications

Technical Data

Increase the safety and speed of electrical thermography

If you are concerned about arc-flash but wish to continue with your infrared thermography program, infrared windows are the answer. These arc-resistant, outdoor certified, infrared windows allow thermal, ultraviolet, visual and fusion technologies to be used without exposing personnel to live equipment.

All infrared windows from Fluke use the unique Quadraband™ multispectral optic, allowing inspection with any camera for total flexibility both now and in the future.

- Engineered and tested to withstand electric-arcs up to 50 kA for 30 cycles.
- Certified by UL & CSA for Type 3/12 (Outdoor) environments in North America and Canada, the C-Range windows are tested to withstand the long term aging effects of UV exposure.
- Certified by SIRA Certification IP65 (Outdoor) environments in Europe.
- The CLIRVU® coating—exclusive to Fluke Windows—seals the optic prior to assembly to protect against moisture degradation.
- Own a Fluke Camera? The Quadraband™ optic is IR-Fusion® compatible, allowing the thermographer to see potential problems in visual light and thermographic mode.
- Got more than one window per panel? Each C-Range window is delivered with an identification plate attached for unique, on-site numbering for rapid location confirmation and faster repairs.
- Each infrared window comes complete with a security access key, installation instructions and self-adhesive drilling template.



Exclusive to Fluke IR Windows, allows you to inspect your equipment with four different types of cameras. Provides maximum flexibility to upgrade or swap out inspection cameras without any IR Window replacement. No other IR Windows manufacturer gives you that flexibility.



Clirvu II Quadraband™

AutoGround™

Automatically grounds at installation for maximum safety and compliance. No additional steps or testing is required. Only available on Fluke IR Windows.



AutoGrounding™

Detailed specifications

	3460346 FLK-050-CLKT	3460387 FLK-075-CLKT	3460439 FLK-100-CLKT
Optic data			
Crystal insert diameter	50 mm (1.97 in)	75 mm (2.96 in)	100 mm (3.94 in)
Viewing aperture diameter	43 mm (1.7 in)	68 mm (2.7 in)	89 mm (3.5 in)
Viewing aperture area	1452 mm ² (2.25 sq in)	3632 mm ² (5.63 sq in)	6322 mm ² (9.79 sq in)
Thickness	2 mm (0.08 in)	2 mm (0.08 in)	4 mm (0.16 in)
CLIRVU coating	Yes		
Shortwave IR capable	Yes		
Midwave IR capable	Yes		
Longwave IR capable	Yes		
Ultraviolet (UV) capable	Yes		
Visual capable	Yes		
Fusion capable	Yes		

Why is available area important?

Understanding the difference between “Optic Diameter” and “Available Area” gives the thermographer a measure of how much infrared energy is passing through the window. The more energy, the better the reading. The entire area of a crystal IR Window is available for infrared transmission for optimum repeatable results.

Mesh grids may have a larger “optic diameter” but the grid itself blocks the IR signal. The amount of radiation available to the camera via mesh windows is significantly reduced and the signal may be irregular.

Underwriters Laboratories (UL) recognized	Yes
UL50 environmental	Type 3/12
UL746C	N/A (Polymer Free)
UL94	N/A (Polymer Free)
Canadian Standards Association (CSA) approval	Yes
Environmental	Type 3/12
KEMA (Arc-Testing)	
ANSI C37.20.7	50 kA for 30 cycles @60 Hz
EEMACS 14-1 Type-B	40 kA for 30 cycles @60 Hz
ASTA (Arc-Testing)	
IEC 62271	20 kA for 5 cycles @50 Hz
TUV	
Cyclic humidity withstand	Yes
Vibration withstand	Yes
NEMKO	
Resistance of insulating materials to 100°	Yes
Resistance of insulating material to ball pressure (Brinell)	Yes
Glow-wire test 650 °C	Yes
Lloyds Register	
Up to 11 kV marine switchgear, indoor or outdoor	Yes

General specifications

Maximum temperature	Gaskets: 250 °C (482 °F)
	Body: 659 °C (1219 °F)
	Optic: 1400 °C (2552 °F)
Gaskets	Low smoke and fume (LSF) compliant silicone
IP rating	IP65
NEMA rating	Type 3/12 (UL and CSA Third Party Certified)
Vibration rating	IEC60068-2-6
Humidity rating	IEC60068-2-3
Pull-out strength	Up to 630 kg (1388 lb)
Warranty	Lifetime replacement against manufacturing defects

Ordering information

Crystal insert size	50 mm (2 in)	75 mm (3 in)	100 mm (4 in)
	3460346 FLK-050-CLKT	3460387 FLK-075-CLKT	3460439 FLK-100-CLKT
Kwik-twist aluminium cover	KT	KT	KT

Included with product

IR Windows are supplied complete, assembled and ready for installation. In addition to the IR Window each carton contains an installation CD, self-adhesive drilling template, security access key, warranty statement.

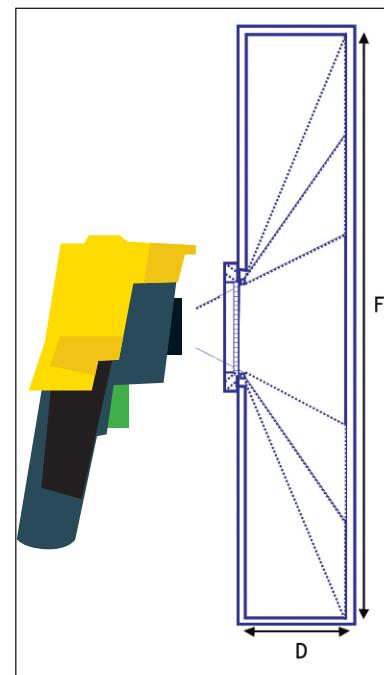

Basic Field of View (FOV) calculation, $F = 6 \times D$

Fluke. *Not just infrared.*
Infrared you can use.™

Fluke Corporation
PO Box 9090, Everett, WA 98206 U.S.A.

Fluke Europe B.V.
PO Box 1186, 5602 BD
Eindhoven, The Netherlands

For more information call:
In the U.S.A. (800) 443-5853 or
Fax (425) 446-5116
In Europe/M-East/Africa +31 (0) 40 2675 200 or
Fax +31 (0) 40 2675 222
In Canada (800)-36-FLUKE or
Fax (905) 890-6866
From other countries +1 (425) 446-5500 or
Fax +1 (425) 446-5116
Web access: <http://www.fluke.com>

©2009-2010 Fluke Corporation.
Specifications subject to change without notice.
Printed in U.S.A. 7/2010 3504172D D-EN-N

**Modification of this document is not permitted
without written permission from Fluke Corporation.**