

MODEL 682 DUCTLESS CEILING/WALL FAN

MODEL 682L DUCTLESS FAN/LIGHT

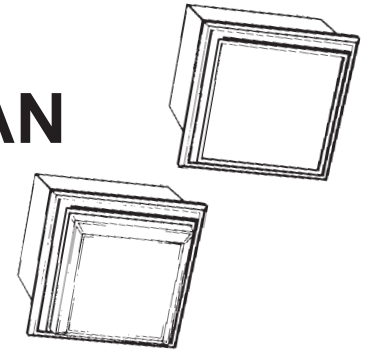

Processes air to eliminate odors where ductwork is impossible.

FEATURES

GRILLE:

- Attractive, self-adjusting grille conceals fan interior
- White, polymeric - blends well with any decor
- Torsion spring grille mounting - no tools required
- Built-in light diffusing lens accepts up to 100 W bulb (Model 682L Only - bulb not included)

MOTOR:

- Plug-in, removable motor assembly
- Polymeric impeller

HOUSING:

- Patented snap-in mounting saves time and money
- Mounts easily to framing
- Long-lasting activated charcoal filter - easy to replace

Controls designed for use with these products (purchase separately):

- Model 57V (Ivory) / 57W (White) Electronic Variable Speed Control - 3 amp
- Model 69V (Ivory) / 69W (White) Single-Function Control
- Model 68V (Ivory) / 68W (White) Two-Function Control

SPECIFICATIONS

MODEL	VOLTS	AMPS
682	120	1.0
682L	120	1.5



TYPICAL SPECIFICATION

Ventilator shall be Broan Model 682 (Broan Model 682L).

Unit shall have steel housing with snap-in mounting system.

Fan to have activated charcoal filter. Motor assembly shall be removable for cleaning and service.

Grille to be self-adjusting and require no tools to install or remove. Lamp capacity must be 100 Watts (Model 682L).

Unit shall be U.L. Listed.

Must be Type I.C. (Model 682L only).

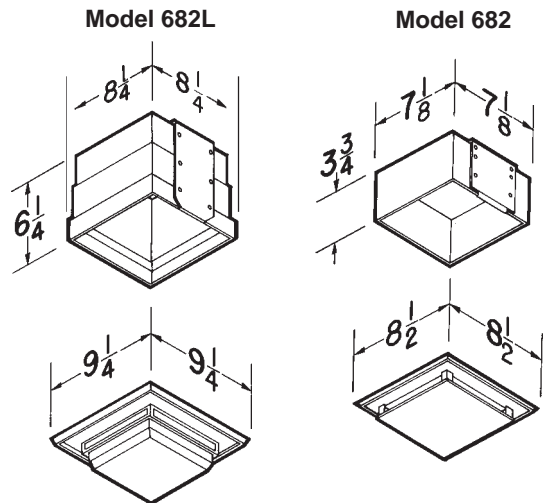

Broan-NuTone LLC, A Nortek Company, Hartford, Wisconsin 53027

REFERENCE	QTY.	REMARKS	Project
			Location
			Architect
			Engineer
			Contractor
			Submitted by Date